

Clamping devices

General description:

CLAMPEX® are keyless clamping devices designed to transmit torque via friction on mating components. These designs produce high transmittable torque while providing uniform loading. They are available in a variety of designs and configurations to accommodate application requirements.

Function and Design

CLAMPEX® are keyless clamping devices utilizing a dual taper design to frictionally connect a shaft and a hub. An even clamping force is obtained by tightening the locking bolts allowing **CLAMPEX®** to transmit high torques, axial loads and bending moments.

High transmittable torque is obtained by introducing normal force directly into mating components. Large uniform force is evenly applied by means of precision tapers contained within each device that produces uniform stress levels in mating components. High grade bolts ensure consistent tightening torque and repeatability. These, along with the corrosion resistant coatings, enable devices to be used multiple times.

Keyless clamping devices with a variety of standard clamping options accommodate shafts up to 600 millimeters and a maximum nominal torque of 7,057,640 lb-in. The all metallic design makes **CLAMPEX®** suitable for high temperature applications.

Factors like cost reduction, material saving, simplified production processes, shorter delivery times of material are already determined by design and development.

CLAMPEX® clamping elements

offer new possibilities as a shaft-hub-connection:

- 1 Material saving using smaller shaft and hub dimensions
- 1 Simplified production processes
- 1 Suitable for modern drive systems
- 1 Easy assembly and disassembly with standard tools
- 1 Ideal for drives with high vibratory loads, e. g. acceleration and braking
- 1 Produce connections that are permanently free from destruction, i. e. no shearing off of keyways, dowel pins, pins, etc.
- 1 Specifically suitable for high-speed drives
- 1 Insensitive to dirt
- 1 Reusable
- 1 Overload protection of the machine components by slipping (repeated slipping should be avoided)
- 1 Low stress concentration on the shaft (stress concentration factor on request)
- 1 Corrosion and acid-resistant surface coating for food processing industry, marine industry and chemical industry on request
- 1 Simple calculation of the clamping connection

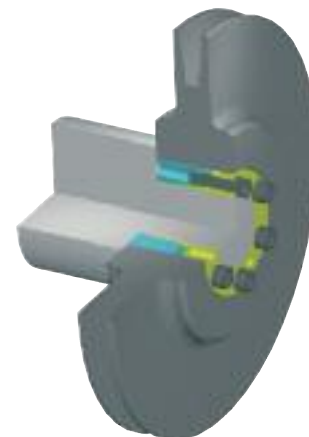
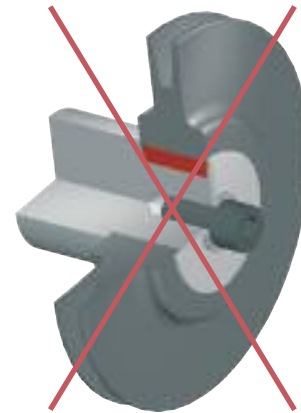

Advice for selection:

The transmission data stated in the catalog are calculated.

Subject to tests and the physical coefficient of friction, slight deviations from the transmission values may arise.

Copyright according to ISO 16016.

We reserve the right for modifications of dimensions and designs.

KTR 620



- 1 Applications with hollow shafts, bushings, couplings, mechanical shrink connections
- 1 Suitable for high transmittable torques
- 1 Ease of assembly with visual mounting groove
- 1 Corrosion-resistant outer ring (phosphated)
- 1 Suitable for high speeds
- 1 Installation instructions available at www.ktr.com

Outer ring
phosphated with
taper contact
surfaces lubricated

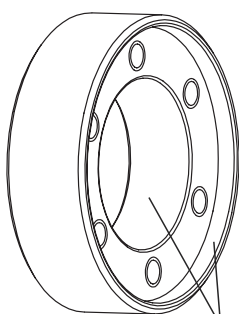

Inner ring

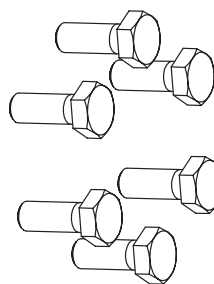
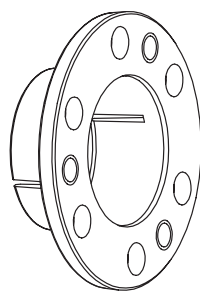

greased

Assembly

Clean and degrease the contact surfaces of the shaft and hub bore (hollow shafts). Slightly loosen the fasteners and put the clamping unit into the hub bore and shaft. Tighten each fastener evenly in a cross pattern until the front surfaces of the outer and inner rings are flush. Do not exceed the max. tightening torque of the fasteners. The values for T and Fax shown in the table relate to an assembly with a lubricated external clamping device. The external clamping devices are delivered pre-lubricated. When assembling unlubricated external clamping devices, the values shown in the table and the values calculated are different. If you have questions, please contact KTR.

Note: Contact surfaces of the shaft and hub bore (hollow shaft) must not be lubricated.

Disassembly

All fasteners must be loosened evenly in a cross pattern. Do not completely unscrew the fasteners from the threads. Loosen the external taper ring and the inner ring with the removal thread.

Tolerances, surfaces

Typical turning process is sufficient:

$$RZ \leq 630\mu\text{in}$$

Maximum allowable tolerances

d = f7 for the hub bore

$$d_w = h6/H7$$

$$d_w > \varnothing 160 - g6/H7$$

Axial movement

KTR 620: There is no axial movement of the hub towards the shaft while tightening the fasteners.

Order form:	KTR 620	20	x	47
	Design	Size of inside diameter		Size of outside diameter

KTR 620 – Technical Data



Frictionally mounted connection of a DATAFLEX® torque measuring unit installed with a KTR 620

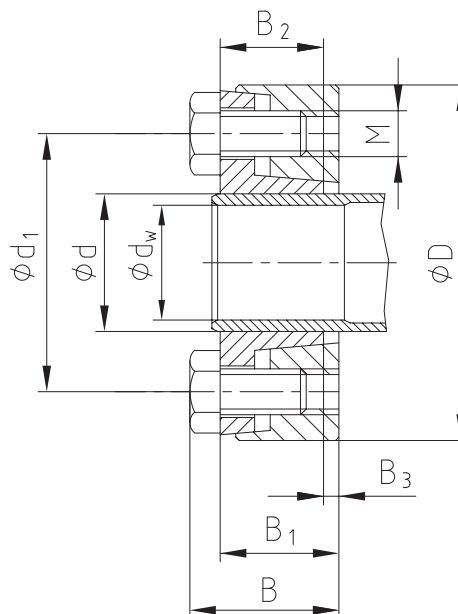

CLAMPEX® – KTR 620															
d x D [mm]	Shaft diameter d _w [mm]	Transmittable torque or axial force		Dimensions [in]					Fasteners DIN EN ISO 4017 - 10.9 μ _{total} =0.10			Jack thread		Surface pressure on shaft	Weight [lbs]
		T [lb-in]	F _{ax} [lbf]	B	B ₁	B ₂	B ₃	d ₁	M	z Quantity	T _A [lb-in]	M ₁	z ₁ Quantity	P _H (psi)	
16x41	13	750	2,920	0.75	0.59	0.51	0.08	1.10	M6	3	106	M6	2	40,740	0.33
	14	920	3,370												
20x47	17	1,370	4,050	0.75	0.59	0.51	0.08	1.26	M6	4	106	M6	2	41,760	0.37
	18	1,540	4,270												
24x50	20	2,070	5,400	0.87	0.71	0.63	0.08	1.42	M6	5	106	M6	2	38,570	0.55
	22	2,690	6,300												
	24	3,450	7,420												
30x60	25	3,800	7,650	0.94	0.79	0.71	0.08	1.73	M6	6	106	M6	3	37,120	0.66
	26	4,240	8,320												
	27	4,510	8,550												
36x72	30	6,100	10,350	1.08	0.87	0.79	0.08	2.05	M8	5	266	M8	2	37,120	1.08
	33	7,250	11,250												
40x80	34	8,050	12,150	1.16	0.94	0.87	0.08	2.40	M10	6	266	M8	2	36,830	1.35
	35	7,520	11,020												
	37	8,670	11,920												
50x90	38	10,440	13,950	1.24	1.02	0.93	0.10	2.68	M13	8	266	M8	2	36,100	1.85
	40	11,680	14,850												
	42	13,010	15,750												
55x100	42	12,390	15,070	1.36	1.14	1.02	0.12	2.83	M16	8	266	M8	2	32,330	2.65
	45	14,600	16,420												
	48	16,810	17,770												
60x110	48	15,040	15,970	1.36	1.14	1.02	0.12	3.15	M19	9	266	M8	3	32,330	3.31
	50	18,140	18,450												
	52	19,470	19,120												
68x115	50	16,810	17,100	1.36	1.14	1.02	0.12	3.39	M22	9	266	M8	3	32,190	3.53
	55	21,680	20,020												
	60	26,550	22,500												
75x138	55	23,450	21,600	1.50	1.22	1.06	0.16	3.94	M25	10	522	M10	2	32,910	5.73
	60	28,760	24,300												
	65	34,070	26,550												
80x141	60	29,650	25,200	1.50	1.22	1.06	0.16	4.09	M28	10	522	M10	2	32,480	6.17
	65	35,220	27,450												
	70	40,890	29,700												

Additional sizes are available upon request.

Inner ring slotted up to size 40 x 80, all sizes of outer ring are phosphate coated.

KTR 620 – Technical Data



Frictionally mounted connection of a DATAFLEX® torque measuring unit installed with a KTR 620

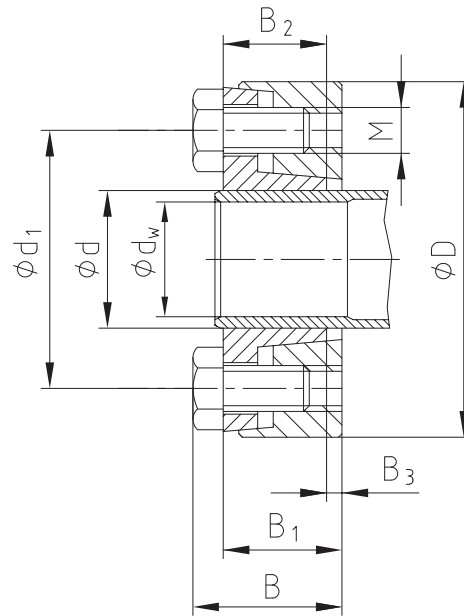

CLAMPEX® – KTR 620															
d x D [mm]	Shaft diameter d _w [mm]	Transmittable torque or axial force		Dimensions [in]					Fasteners DIN EN ISO 4017 - 10.9 μ _{total} =0.10			Jack threads		Surface Pressure on Shaft	Weight [lb]
		T [lb-in]	F _{ax} [lbf]	B	B ₁	B ₂	B ₃	d ₁	M	z Quantity	T _A [lb-in]	M ₁	z ₁ Quantity	P _H [psi]	
90x155	65	46,020	36,000												
	70	53,100	38,470	1.77	1.50	1.34	0.16	4.49	M10	11	522	M10	2	31,760	7.50
	75	61,070	41,400												
100x170	70	58,410	42,520												
	75	67,260	45,670	1.97	1.69	1.54	0.16	4.88	M10	14	522	M10	3	29,870	10.1
	80	76,110	48,370												
110x185	80	93,820	59,620												
	85	105,320	63,000	2.24	1.93	1.73	0.20	5.35	M12	12	885	M12	4	30,740	13.7
	90	117,710	66,600												
120x197	85	112,400	67,270												
	90	125,680	71,100	2.40	2.09	1.89	0.20	5.79	M12	14	885	M12	4	29,730	16.3
	95	138,960	74,470												
125x215	90	129,220	72,900												
	95	141,610	75,820	2.40	2.09	1.89	0.20	6.22	M12	14	885	M12	4	31,180	20.5
	100	154,890	78,750												
130x230	95	164,620	88,200												
	100	179,670	91,350	2.64	2.28	2.05	0.24	6.50	M14	9	1,416	M14	4	32,630	26.2
	110	208,880	96,520												
140x230	100	177,900	90,450												
	105	192,060	92,920	2.64	2.28	2.05	0.24	6.77	M14	9	1,416	M14	4	29,730	24.3
	115	222,600	98,320												
155x263	110	242,510	112,050												
	115	261,980	115,870	2.80	2.44	2.20	0.24	7.32	M14	10	1,416	M14	4	30,740	35.3
	125	283,230	119,920												
165x290	120	367,310	155,700												
	125	392,090	159,520	3.07	2.68	2.40	0.28	8.03	M16	12	2,213	M16	4	32,340	49.2
	135	417,760	163,350												
175x300	130	421,300	164,700												
	135	446,970	168,300	3.07	2.68	2.40	0.28	8.43	M16	12	2,213	M16	4	31,320	51.4
	140	473,520	171,900												
185x320	140	584,160	212,170												
	145	618,680	216,900	3.74	3.35	3.03	0.31	8.82	M16	14	2,213	M16	4	29,150	73.6
	150	650,540	220,500												

Additional sizes are available upon request.

Inner ring slotted up to size 40 x 80, all sizes of outer ring are phosphate coated.

KTR 603



- 1 Standard external clamping device
- 1 For average to high transmittable torques
- 1 Typical applications: hollow shafts, bushings
- 1 KTR 603 GT separated external clamping device (Please request drawing M483039)
- 1 Installation instructions available at www.ktr.com

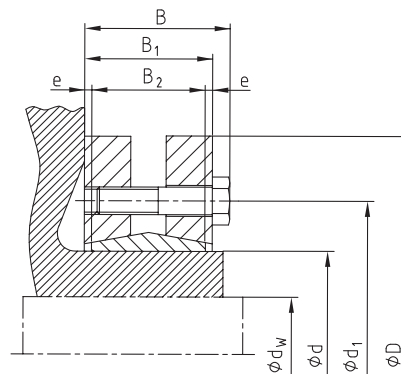

Assembly

Clean and degrease the contact surfaces of the shaft and hub bore (hollow shafts). Assemble the external clamping device onto the hub (outer hollow shaft). In the area of the external clamping device, the external surface of the hub (outer hollow shaft) can be lubricated. Slightly loosen the fasteners and slide the clamping unit onto the hub (hollow shaft). Before tightening the fasteners please insert the shaft. Tighten each fastener evenly one after another until the front surfaces of the outer and inner rings are flush. Do not exceed the max. tightening torque of the fasteners. The values for T and F_{ax} shown in the table relate to an assembly with a lubricated external clamping device. The external clamping devices are delivered pre-lubricated. When assembling unlubricated external clamping devices, the values shown in the table and the values calculated are different. If you have questions, please contact KTR.

Note: Do not use any oil with molybdenum sulfide between the contact surfaces of device and hub to shaft bore (hollow shaft).

Disassembly

All fasteners must be loosened evenly one after another. Do not completely unscrew the fasteners from the threads. The clamping unit should release automatically.

Tolerances, surfaces

Typical turning process is sufficient:

$RZ \leq 630\mu\text{in}$

Maximum allowable tolerances:

$d = h8$ for the shaft

Tolerances for dw

For dw from 18 to 30 mm **H6 / j6**

For dw from 51 to 80 mm **H6 / g6**

For dw from 31 to 50 mm **H6 / h6**

For dw from 81 to 500 mm **H7 / g6**

* In general greater tolerances are possible. Please contact KTR.

Axial movement

KTR 603: There is no axial movement of the hub towards the shaft while tightening the fasteners.

Order form:	KTR 603	44	x	80
	Design	Size of inside diameter		Size of outside diameter

KTR 603 – Technical Data

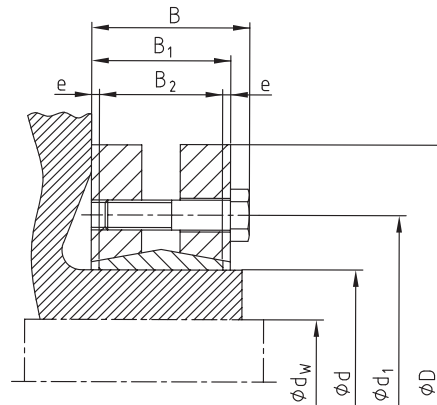

CLAMPEX® – KTR 603														
d x D [mm]	Shaft diameter d_w [mm]	Transmittable torque or axial force		Dimensions [in]					Fasteners DIN EN ISO 4014 - 10.9 $\mu_{total}=0.10$			Surface Pressure on Shaft P_H [psi]	Weight [lb]	
		T [lb-in]	F_{ax} [lbf]	B	B_1	B_2	e	d_1	M	z Quantity	T_A [lb-in]			
14x38	10	240	1,120											
	11	330	1,570	0.57	0.43	0.35	0.04	0.91	M5 1)	4	31	56,260	0.33	
	12	440	2,020											
16x41	12	440	2,020											
	13	610	2,250	0.73	0.59	0.43	0.08	1.02	M5 1)	5	35	44,950	0.44	
	14	790	2,920											
24x50	19	1,850	4,950											
	20	2,300	5,850	0.89	0.75	0.55	0.10	1.42	M5 1)	6	44	41,470	0.44	
	21	2,740	6,520											
30x60	24	2,740	5,620											
	25	3,000	6,070	0.96	0.83	0.63	0.10	1.73	M5 1)	6	53	33,780	0.66	
	26	3,360	6,520											
36x72	28	4,070	7,420											
	30	5,220	8,770	1.06	0.91	0.71	0.10	2.05	M6	5	106	44,510	0.99	
	31	5,570	9,000											
44x80	32	5,570	9,000											
	35	6,900	9,900	1.14	0.98	0.79	0.10	2.40	M6	7	106	45,960	1.32	
	36	7,610	10,800											
50x90	38	8,310	11,020											
	40	9,730	12,370	1.22	1.06	0.87	0.10	2.76	M6	8	106	41,900	1.76	
	42	11,500	13,950											
55x100	42	10,620	12,820											
	45	13,270	14,850	1.34	1.18	0.91	0.14	2.95	M6	8	106	36,540	2.43	
	48	16,810	17,770											
62x110	48	15,930	16,870											
	50	19,470	19,800	1.34	1.18	0.91	0.14	3.39	M6	10	106	40,450	2.87	
	52	21,240	20,700											
68x115	50	17,700	18,000											
	55	22,120	20,470	1.34	1.18	0.91	0.14	3.39	M6	10	106	36,970	3.09	
	60	27,430	23,170											
75x138	55	22,120	20,700											
	60	28,320	24,070	1.48	1.26	0.98	0.14	3.94	M8	7	266	39,580	3.75	
	65	34,510	27,220											
80x145	60	28,320	24,070											
	65	34,510	27,000	1.48	1.26	0.98	0.14	3.94	M8	7	266	37,120	4.85	
	70	40,710	29,470											
85x155	65	42,480	33,300											
	70	53,990	39,370	1.71	1.50	1.18	0.16	4.49	M8	10	266	41,320	7.50	
	75	65,490	45,220											
90x155	65	41,590	32,620											
	70	53,100	38,700	1.75	1.54	1.18	0.18	4.49	M8	10	266	39,290	7.28	
	75	63,720	43,650											

1) The fasteners are designed per DIN EN ISO 4014 – 8.8 with $\mu_{total}=0.12$.
Additional sizes are available upon request.

KTR 603 – Technical data

CLAMPEX® – KTR 603														
d x D [mm]	Shaft diameter d _w [mm]	Transmittable torque or axial force		Dimensions [in]					Fasteners DIN EN ISO 4014 - 10.9 μ _{total} =0.10			Surface Pressure on Shaft P _H [psi]	Weight [lb]	
		T [lb-in]	F _{ax} [lbf]	B	B ₁	B ₂	e	d ₁	M	z Quantity	T _A [lb-in]			
100x170	70	61,070	44,770											
	75	66,380	44,770	1.95	1.73	1.34	0.20	4.88	M8	12	266	37,410	10.1	
	80	79,650	50,620											
110x185	75	63,720	43,650											
	80	79,650	51,070	2.22	1.97	1.54	0.22	5.35	M10	9	522	35,380	13.0	
	85	97,360	58,270											
115x188	80	75,230	47,920											
	85	88,510	53,320	2.22	1.97	1.54	0.22	5.55	M10	9	522	33,930	13.9	
	90	106,210	60,070											
120x215	80	93,820	60,070											
	85	117,710	70,200	2.30	2.05	1.65	0.20	6.30	M10	12	522	40,160	17.6	
	90	128,330	72,900											
125x215	85	97,360	58,720											
	90	115,060	65,250	2.30	2.05	1.65	0.20	6.30	M10	12	522	38,570	19.0	
	95	132,760	71,550											
130x215	90	121,250	68,850											
	95	139,840	75,150	2.30	2.05	1.65	0.20	6.30	M10	12	522	41,320	18.1	
	100	161,080	82,120											
140x230	95	132,760	78,750											
	100	150,460	76,950	2.66	2.36	1.81	0.28	6.89	M12	10	885	38,280	22.1	
	105	177,020	85,950											
155x263	105	177,020	85,720											
	110	203,570	93,370	2.81	2.52	1.97	0.28	7.56	M12	12	885	38,130	33.1	
	115	230,120	101,920											
165x290	115	318,630	140,850											
	120	345,180	145,800	3.09	2.80	2.20	0.30	8.27	M16	8	2,213	40,160	48.5	
	125	389,440	157,950											
175x300	125	354,040	144,450											
	130	389,440	152,320	3.19	2.80	2.20	0.30	8.66	M16	8	2,213	37,840	50.7	
	135	433,690	163,350											
185x330	135	486,800	183,600											
	140	531,060	192,370	3.78	3.39	2.80	0.30	9.29	M16	10	2,213	35,380	79.4	
	145	575,310	202,950											
195x350	140	584,160	212,170											
	150	672,670	227,920	3.78	3.39	2.80	0.30	9.69	M16	12	2,213	40,160	88.2	
	155	725,780	237,820											
200x350	150	654,970	220,950											
	155	708,080	232,870	3.78	3.39	2.80	0.30	9.69	M16	12	2,213	39,150	106	
	160	761,180	243,220											
220x370	160	840,840	268,650											
	165	902,800	279,900	4.49	4.09	3.46	0.31	10.63	M16	15	2,213	35,960	119	
	170	973,610	290,920											
240x405	170	1,062,120	316,800											
	180	1,239,140	350,550	4.78	4.29	3.62	0.33	11.61	M20	12	4,337	39,440	148	
	190	1,416,160	380,250											
260x430	190	1,460,410	332,100											
	200	1,637,430	416,470	5.18	4.69	4.06	0.31	12.64	M20	14	4,337	37,990	181	
	210	1,814,450	438,750											
280x460	210	1,920,660	465,070											
	220	2,159,640	499,950	5.77	5.28	4.49	0.39	13.62	M20	16	4,337	36,390	225	
	230	2,389,770	529,200											
300x485	230	2,434,020	538,870											
	240	2,611,040	554,400	6.08	5.59	4.80	0.39	14.33	M20	18	4,337	35,670	260	
	245	2,788,060	579,150											

1) The fasteners are designed per DIN EN ISO 4014 – 8.8 with μ_{total}=0.12.
Additional sizes are available upon request.

KTR 105 (self-centering)



- 1 Compact internal design
- 1 Ease of assembly
- 1 Suitable for small servo drives/pulleys
- 1 QPQ surface treatment on request
- 1 Installation instructions available at www.ktr.com

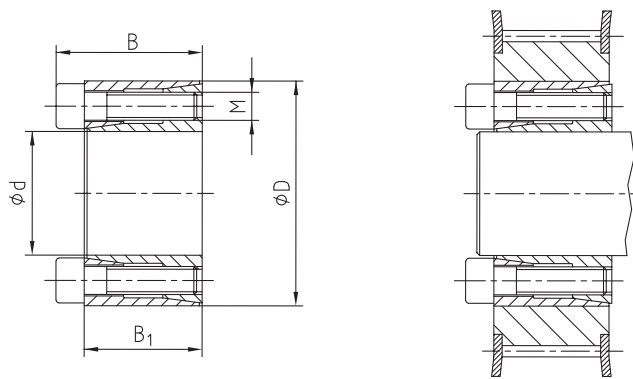

Assembly

Clean and lightly oil the contact surfaces of the shaft and hub bore. Slightly loosen the fasteners and put the clamping unit into the hub bore and shaft. Tighten each fastener evenly in a cross pattern until the front surfaces of the outer and inner rings are flush. Do not exceed the max. tightening torque of the fasteners. The values for T and F_{ax} shown in the table relate to an assembly with a lubricated clamping device. The clamping devices are delivered pre-lubricated. When assembling unlubricated clamping devices, the values shown in the table and the values calculated are different. If you have questions, please contact KTR.

Note: Do not use any oil with molybdenum sulfide or high-pressure lubrication or grease between the contact surfaces of device and hub to shaft.

Disassembly

All fasteners must be removed in an even cross pattern. Insert the fasteners into the backing threads, tighten them in an even cross pattern until the tapered ring is free. For repeatability use oil on the fasteners and threads.

Tolerances, surfaces

Typical turning process is sufficient:

$$RZ \leq 630\mu\text{in}$$

Maximum allowable tolerances:

h9 for the shaft - H9 for the hub

Axial movement

KTR 105: A slight axial movement may occur between the hub and the shaft during assembly.

Concentricity

KTR 105 is **self-centering**. The concentricity of the clamping device is **0.0008 in. to 0.0016 in.** between the hub and the shaft.

Order form:	KTR 105	8	x	18
	Design	Size of inside diameter		Size of outside diameter

KTR 105 (self-centering) – Technical data

CLAMPEX® – KTR 105										
d x D [mm]	Dimensions [in]		Fasteners DIN EN ISO 4762 - 12.9 $\mu_{total}=0.14$			Transmittable torque or axial force		Surface Pressure on Shaft		Weight [lb]
	B	B ₁	M	z Number	T _A ¹⁾ [lb-in]	T [lb-in]	F _{ax} [lbf]	Shaft P _W [psi]	Hub P _N [psi]	
5x16						50		28,420	8,840	0.02
6x16						70		23,630	8,840	0.03
6.35x16	0.53	0.43	M2.5	3	11	70	670	22,330	8,840	0.03
7x17						70		20,300	8,410	0.03
8x18	0.53	0.43		3		80		17,830		0.03
9x20	0.61	0.51	M2.5	4	11	140	670	17,540	7,830	0.04
9.53x20	0.61	0.51		4		140		16,670		0.04
10x20						150		15,800	7,830	0.04
11x22	0.61	0.51	M2.5	4	11	160	670	14,350	7,250	0.05
12x22						180		13,190	7,250	0.05
14x26	0.79		M3		19	350	1,350	14,060	7,540	0.09
15x28	0.79	0.67	M3	4	19	380	1,350	13,050	6,960	0.10
16x32	0.83		M4		43	700	2,250	21,600	10,730	0.15
17x35						750		16,240		0.20
18x35	0.98	0.83	M4	4	43	790	2,250	15,370	7,830	0.19
19x35						840		14,500		0.18
20x38	1.02	0.83	M5		89	1,450	3,600	22,470	11,890	0.22
22x40	1.02	0.83	M5	4	89	1,590	3,600	20,440	11,310	0.24
24x47	1.26	1.02	M6		150	2,460	5,170	21,170	10,870	0.44
25x47				4		2,550	5,170	20,300	10,870	0.42
28x50	1.26	1.02	M6	6	150	4,300	7,870	27,260	15,220	0.49
30x55				6		4,600	7,870	25,370	13,920	0.60
32x55	1.26	1.02		6		4,910	7,870	23,780	13,920	0.55
35x60	1.46	1.22	M6	8	150	7,160	10,350	25,080	14,640	0.79
38x65	1.46	1.22		8		7,780	10,350	23,050	13,480	0.95
40x65	1.46	1.22	M6		150	8,180	10,350	21,890	13,480	0.88
42x75	1.73	1.42	M8	6	363	11,910	14,400	24,650	13,770	1.48
45x75	1.73	1.42	M8		363	12,760	14,400	23,050	13,770	1.39
48x80				8		18,160		28,710		1.63
50x80	1.73	1.42	M8	8	363	18,910	19,120	27,690	17,250	1.54

1) These are the maximum tightening torques. They can be reduced to max. 40% of the figures above with T, F_{ax}, P_W and P_N being reduced proportionally.

KTR 200 and KTR 201 (self-centering)



- 1 Clamping device for general applications
- 1 Economical solution with average to high torques
- 1 Installation instructions available at www.ktr.com

KTR 200

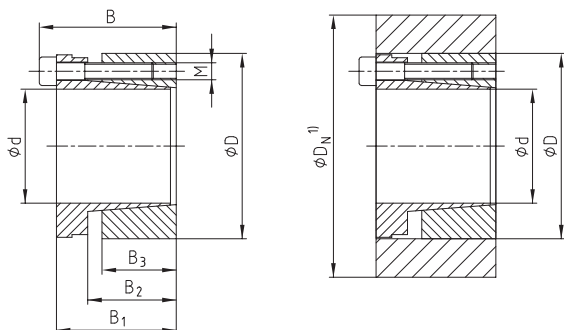

Higher transmittable torque than KTR 201,
slight axial movement of the hub

KTR 201

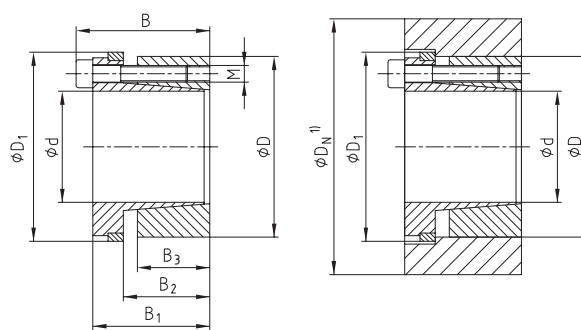

No axial movement of the hub,
but lower transmittable torque than KTR 200

1) Dimension D_N : To calculate see pages 220/221.

Assembly

Clean and lightly oil the contact surfaces of the shaft and hub bore. Slightly loosen the fasteners and put the clamping unit into the hub bore and shaft. Tighten each fastener evenly in a cross pattern until the front surfaces of the outer and inner rings are flush. Do not exceed the max. tightening torque of the fasteners. The values for T and F_{ax} shown in the table relate to an assembly with a lubricated clamping device. The clamping devices are delivered pre-lubricated. When assembling unlubricated clamping devices, the values shown in the table and the values calculated are different. If you have questions, please contact KTR.

Note: Do not use any oil with molybdenum sulfide or high-pressure lubrication or grease between the contact surfaces of device and hub to shaft.

Disassembly

All fasteners must be removed in an even cross pattern. Insert the fasteners into the backing threads, tighten them in an even cross pattern until the tapered ring is free. For repeatability use oil on the fasteners and threads.

Tolerances, surfaces

Typical turning process is sufficient:

$RZ \leq 630\mu\text{in}$

Maximum allowable tolerances:

h8 for the shaft - H8 for the hub

Concentricity

KTR 200 and KTR 201 are **self-centering**. The concentricity of the clamping device is **0.0008 in to 0.0016 in** between the hub and the shaft.

Order form:	KTR 200	40	x	65
	Design	Size of inside diameter		Size of outside diameter

KTR 200 and KTR 201 (self-centering)

CLAMPEX® – KTR 200 and KTR 201																			
d x D [mm]	Dimensions [in]					Fasteners DIN EN ISO 4762 - 12.9 $\mu_{total}=0.14$				KTR 200				KTR 201					
										Transmittable torque or axial force		Surface Pressure on Shaft		Weight [lb]	Transmittable torque or axial force		Surface Pressure on Shaft		Weight [lb]
	B	B ₁	B ₂	B ₃	D ₁	M	z Number	T _A ¹⁾ [lb-in] KTR 200	KTR 201	T [lb-in]	F _{ax} [lbf]	Shaft P _W [psi]	Hub P _N [psi]		T [lb-in]	F _{ax} [lbf]	Shaft P _W [psi]	Hub P _N [psi]	
20x47										4,540		42,190	17,980	0.90	2,930		25,810	11,020	0.93
22x47	1.89	1.65	1.22	1.02	2.09	M6	6	150	150	4,990	11,470	38,280	17,980	0.84	3,230	7,420	23,490	11,020	0.86
24x50										5,450		35,090	16,820	0.93	3,530		21,600	10,290	0.95
25x50										5,670		33,780	16,820	0.90	3,670		20,730	10,290	0.93
28x55	1.89	1.65	1.22	1.02	2.20	M6	6	150	150	6,350	11,470	30,160	15,370	1.10	4,110	7,420	18,410	9,420	1.12
30x55										6,800		28,130	15,370	1.04	4,410		17,250	9,420	1.06
32x60										9,680		35,090	18,700	1.23	6,270		21,600	11,450	1.26
35x60	1.89	1.65	1.22	1.02	2.60	M6	6	150	150	10,590	15,300	32,190	18,700	1.17	6,860	9,900	19,720	11,450	1.19
38x65										11,490		29,580	17,250	1.37	7,450		18,120	10,580	1.39
40x65	1.89	1.65	1.22	1.02	2.80	M6	8	150	150	12,100	15,300	28,130	17,250	1.26	7,840	9,900	17,250	10,580	1.28
42x75	2.32	2.01	1.38	1.18	3.19	M8	6	360	360	17,610	21,370	32,190	17,980	2.23	11,410	13,720	19,720	11,020	2.25
45x75	2.32	2.01	1.38	1.18	3.19	M8	6	360	360	18,870	21,370	30,010	17,980	2.16	12,230	13,720	18,410	11,020	2.18
48x80					3.39					26,840		37,550	22,470	2.40	17,390		23,050	13,770	2.43
50x80	2.32	2.01	1.38	1.18	3.39	M8	8	360	360	27,960	28,350	35,960	22,470	2.36	18,110	18,450	22,040	13,770	2.38
55x85					3.58					30,750		32,770	21,170	2.54	19,930		20,150	13,050	2.56
60x90	2.32	2.01	1.38	1.18	3.78	M8		360	360	33,550	28,350	30,010	20,010	2.71	21,730	18,450	18,410	12,320	2.73
65x95	2.32	2.01	1.38	1.18	3.98	M8	8	360	360	36,350	28,350	27,690	18,990	2.91	23,550	18,450	16,960	11,600	2.93
70x110	2.76	2.36	1.77	1.57	4.69	M10		730	730	62,160	45,220	30,590	19,430	4.81	40,270	29,250	18,850	12,030	5.05
75x115					4.88		8			66,590	45,220	28,560	18,700	5.07	43,140	29,250	17,540	11,450	5.31
80x120	2.76	2.36	1.77	1.57	5.08	M10	8	730	730	71,030	45,220	26,820	17,830	5.38	46,020	29,250	16,380	11,020	5.64
85x125					5.28		10			94,340	56,470	31,460	21,460	5.62	61,130	36,670	19,280	13,190	5.89
90x130	2.76	2.36	1.77	1.57	5.47	M10	10	730	730	99,890	56,470	29,720	20,590	5.89	64,720	36,670	18,270	12,610	6.17
95x135	2.60	2.36	1.77	1.57	5.67	M10	10	730	730	100,660	53,770	26,970	18,990	6.17	66,390	35,550	16,820	11,890	6.46
100x145	3.15	2.68	2.05	1.77	6.10	M12	8	1,280	1,280	129,280	65,700	27,690	19,140	8.60	83,770	42,520	16,960	11,740	9.04
110x155					6.50		8			142,210	65,700	25,230	17,830	9.26	92,140	42,520	15,510	11,020	9.70
120x165	3.15	2.68	2.05	1.77	6.89	M12	10	1,280	1,280	193,920	82,120	28,850	21,020	9.92	125,650	53,320	17,690	12,900	10.4
130x180					7.40		12			252,100	98,550	32,040	23,050	12.1	163,350	63,900	19,720	14,210	12.7
140x190					7.83		10	1,850	2,030	283,430	102,820	27,980	20,590	14.6	201,140	73,120	18,850	13,770	15.3
150x200	3.54	2.99	2.28	1.97	8.23	M14	12	1,850	2,030	364,420	123,520	31,320	23,490	15.2	258,610	87,750	21,020	15,800	16.0
160x210					8.62		12	1,850	2,030	388,710	123,520	29,290	22,330	16.3	275,850	87,750	19,720	15,080	17.1
170x225					9.21	M14	14	1,850	2,030	481,840	144,000	32,190	24,360	19.0	341,940		21,600	16,380	19.8
180x235	3.54	2.99	2.28	1.97	9.61					510,180		30,450	23,340	20.1	362,060	102,370	20,440	15,660	20.9

1) These are the maximum tightening torques. They can be reduced to max. 40% of the figures above with T, F_{ax}, P_W and P_N being reduced proportionally.

KTR 203 and KTR 206 (self-centering)



- 1 Clamping device for general applications
- 1 Compact design
- 1 Similar operation as KTR 200/201
- 1 Installation instructions available at www.ktr.com

KTR 203

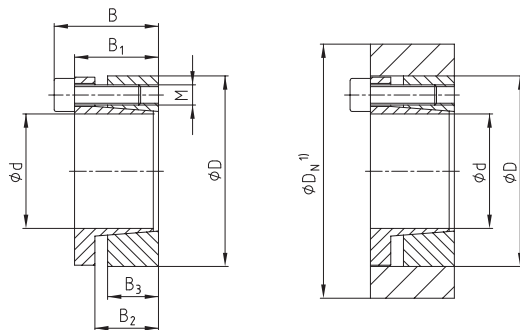

Higher transmittable torque than KTR 206,
slight axial movement of the hub

KTR 206

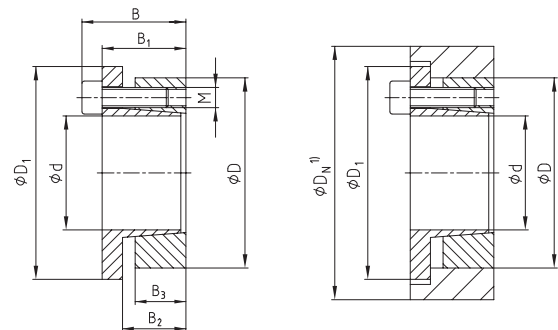

No axial movement of the hub,
but lower transmittable torque than KTR 203

1) Dimension D_N : To calculate see page 220/221.

Assembly

Clean and lightly oil the contact surfaces of the shaft and hub bore. Slightly loosen the fasteners and put the clamping unit into the hub bore and shaft. Tighten each fastener evenly in a cross pattern until the front surfaces of the outer and inner rings are flush. Do not exceed the max. tightening torque of the fasteners. The values for T and F_{ax} shown in the table relate to an assembly with a lubricated clamping device. The clamping devices are delivered pre-lubricated. When assembling unlubricated clamping devices, the values shown in the table and the values calculated are different. If you have questions, please contact KTR.

Note: Do not use any oil with molybdenum sulfide or high-pressure lubrication or grease between the contact surfaces of device and hub to shaft.

Disassembly

All fasteners must be removed in an even cross pattern. Insert the fasteners into the backing threads, tighten them in an even cross pattern until the tapered ring is free. For repeatability use oil on the fasteners and threads.

Tolerances, surfaces

Typical turning process is sufficient:

$RZ \leq 630\mu\text{in}$

Maximum allowable tolerances:

h8 for the shaft - H8 for the hub

Concentricity

KTR 203 and KTR 206 are **self-centering**. The concentricity of the clamping device is **0.0008 in to 0.0016 in** between the hub and the shaft.

Order form:	KTR 203	40	x	65
	Design	Size of inside diameter		Size of outside diameter

KTR 203 and KTR 206 (self-centering) – Technical data

CLAMPEX® – KTR 203 and KTR 206																			
d x D [mm]	Dimensions [in]					Fasteners DIN EN ISO 4762 - 12.9 $\mu_{total}=0.14$				KTR 203				KTR 206					
						M	z Number	$T_A^{1)}$ [lb-in]		T [lb-in]	F_{ax} [lbf]	Surface Pressure on Shaft		Weight [lb]	Transmittable torque or axial force		Surface Pressure on Shaft		Weight [lb]
	KTR 203	KTR 206	Shaft P_W [psi]	Hub P_N [psi]	T [lb-in]			F_{ax} [lbf]	Shaft P_W [psi]			Hub P_N [psi]							
20x47					2.09					3,780		48,430	20,590	0.55	2,930		37,550	15,950	0.57
22x47	1.34	1.10	0.87	0.67	2.09	M6	6	120	150	4,160	9,670	44,080	20,590	0.51	3,230	7,420	34,220	15,950	0.53
24x50					2.20					4,540		40,310	19,430	0.57	3,530		31,320	15,080	0.60
25x50					2.20					4,730		38,710	19,430	0.55	3,670		30,010	15,080	0.57
28x55	1.34	1.10	0.87	0.67	2.42	M6	6	120	150	5,300	9,670	34,650	17,540	0.68	4,110	7,420	26,820	13,630	0.71
30x55					2.42					5,680		32,330	17,540	0.64	4,410		25,080	13,630	0.66
32x60					2.64					8,080		40,310	21,460	0.75	6,270		31,320	16,670	0.77
35x60	1.34	1.10	0.87	0.67	2.64	M6	8	120	150	8,840	12,820	36,830	21,460	0.73	6,860	9,900	28,710	16,670	0.75
38x65					2.83					9,590		33,930	19,860	0.84	7,450		26,390	15,370	0.86
40x65	1.34	1.10	0.87	0.67	2.83	M6		120	150	10,090	12,820	32,330	19,860	0.75	7,840	9,900	25,080	15,370	0.77
42x75	1.61	1.30	0.98	0.79	3.31	M8	8	300	360	19,530	23,620	48,140	26,970	1.30	15,210	18,450	37,550	21,020	1.32
45x75	1.61	1.30	0.98	0.79	3.31	M8		300	360	20,920	23,620	44,950	26,970	1.28	16,300	18,450	34,940	21,020	1.30
48x80					3.50					22,320		42,050	25,230	1.41	17,390		32,770	19,720	1.43
50x80	1.61	1.32	0.94	0.79	3.50	M8	8	300	360	23,250	23,620	40,450	25,230	1.39	18,110	18,450	31,460	19,720	1.41
55x85					3.58					25,570		36,680	23,780	1.52	19,930		28,560	18,560	1.54
60x90	1.61	1.32	0.94	0.79	3.90	M8		300	360	27,890	23,620	33,640	22,470	1.61	21,730	18,450	26,240	17,540	1.63
65x95	1.61	1.32	0.94	0.79	4.09	M8	8	300	360	30,220	23,620	31,030	21,310	1.74	23,550	18,450	24,210	16,530	1.76
70x110	1.97	1.57	1.14	0.94	4.69	M10		610	730	52,520	38,250	38,860	24,650	3.24	40,270	29,250	29,720	18,990	3.48
75x115					4.88		8			56,270	38,250	36,250	23,630	3.42	43,140	29,250	27,840	18,120	3.66
80x120	1.97	1.57	1.14	0.94	5.08	M10	8	610	730	60,020	38,250	33,930	22,620	3.64	46,020	29,250	26,100	17,400	3.90
85x125					5.28		10			79,720	47,700	40,020	27,110	3.79	61,130	36,670	30,590	20,880	4.06
90x130	1.97	1.57	1.14	0.94	5.47	M10	10	610	730	84,410	47,700	37,700	26,100	3.99	64,720	36,670	29,000	20,010	4.28
95x135	1.97	1.57	1.14	0.94	5.67	M10	10	610	730	85,060	45,450	34,070	24,070	4.19	66,390	35,550	26,680	18,700	4.48
100x145	2.20	1.73	1.22	1.02	6.06	M12	8	1,010	1,280	103,720	52,650	34,650	23,920	5.47	83,770	42,520	27,980	19,280	5.91
110x155	2.20	1.73	1.22	1.02	6.46		8			114,090	52,650	31,460	22,330	5.87	92,140	42,520	25,520	18,120	6.31
120x165	2.20	1.73	1.22	1.02	6.85	M12	9	1,010	1,280	140,030	59,400	32,480	23,630	6.26	113,080	47,920	26,240	19,140	6.75
130x180	2.52	2.05	1.54	1.34	7.44		12			202,270	79,200	30,590	22,040	9.81	163,350	63,900	24,650	17,830	10.3
140x190					7.83		9			227,460	82,570	29,720	21,890	10.2	181,020	65,700	23,630	17,400	10.9
150x200	2.68	2.13	1.54	1.34	8.23	M14	10	1,630	2,030	270,790	91,800	30,740	23,050	10.6	215,510	73,120	24,500	18,410	11.3
160x210					8.62		12			346,610	110,250	34,650	26,390	11.4	275,850	87,750	27,550	21,020	12.2
170x225	3.07	2.52	1.93	1.73	9.21	M14	12	1,630	2,030	368,280	110,250	32,620	24,650	16.2	293,100	87,750	25,950	19,570	17.0
180x235					9.61					389,930		30,740	23,630	17.1	310,340	87,750	24,500	18,700	18.0

1) These are the maximum tightening torques. They can be reduced to max. 40% of the figures above with T , F_{ax} , P_W and P_N being reduced proportionally.

KTR 250 (self-centering)



- 1 Clamping device specifically designed for hubs with a thin wall
- 1 Economic compact design
- 1 Ease of assembly
- 1 Low profile tapers reduce bore requirement
- 1 Clamping devices "stainless steel" on request (request table M367697)
- 1 Installation instructions available at www.ktr.com

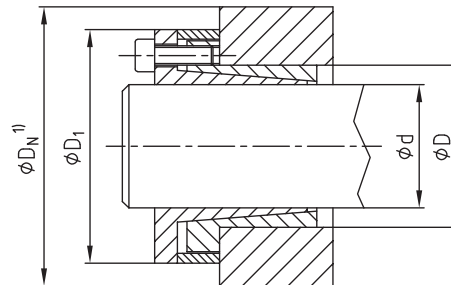
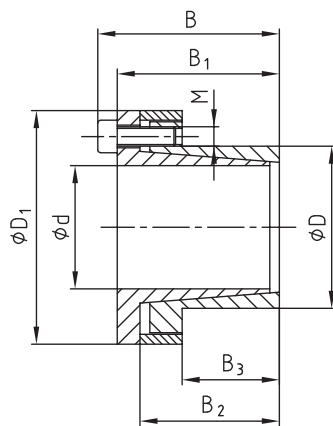

No axial misalignment of the hub during the assembly

1) Dimension D_N : To calculate see page 220/221.

Assembly

Clean and lightly oil the contact surfaces of the shaft and hub bore. Slightly loosen the fasteners and put the clamping unit into the hub bore and shaft. Tighten each fastener evenly in a cross pattern until the front surfaces of the outer and inner rings are flush. Do not exceed the max. tightening torque of the fasteners. The values for T and F_{ax} shown in the table relate to an assembly with a lubricated clamping device. The clamping devices are delivered pre-lubricated. When assembling unlubricated clamping devices, the values shown in the table and the values calculated are different. If you have questions, please contact KTR.

Note: Do not use any oil with molybdenum sulfide or high-pressure lubrication or grease between the contact surfaces of device and hub to shaft.

Disassembly

All fasteners must be removed in an even cross pattern. Insert the fasteners into the backing threads, tighten them in an even cross pattern until the tapered ring is free. For repeatability use oil on the fasteners and threads.

Tolerances, surfaces

Typical turning process is sufficient:
 $RZ \leq 630\mu\text{in}$

Maximum allowable tolerances:
h8 for the shaft - H8 for the hub

Concentricity

KTR 250 is **self-centering**. The concentricity of the clamping device is **0.0008 in to 0.0016 in** between the hub and the shaft.

KTR 250 (self-centering) – Technical data

CLAMPEX® – KTR 250													
d x D [mm]	Dimensions ²⁾ [in]					Fasteners DIN EN ISO 4762 - 12.9 $\mu_{total}=0.14$			Transmittable torque or axial force		Surface Pressure on Shaft		Weight [lb]
	B	B ₁	B ₂	B ₃	D ₁	M	z Number	T _A ¹⁾ [lb-in]	T [lb-in]	F _{ax} [lbf]	Shaft P _W [psi]	Hub P _N [psi]	
6x14	0.94	0.83	0.73	0.39	0.98	M3	4	18	120	1,120	36,540	15,660	0.22
8x15	1.14	0.98	0.87	0.45	1.06	M4	3	44	230	1,570	30,450	16,240	0.26
9x16			0.91	0.55	1.10				350		30,010	16,820	0.33
10x16	1.18	1.02	0.89	0.55	1.14	M4	4	44	400	2,020	27,840	17,400	0.33
11x18			0.91	0.53	1.26				430		24,500	14,930	0.40
12x18	1.18	1.02	0.89	0.53	1.26	M4	4	44	480	2,020	23,200	15,370	0.40
14x23	1.18	1.02	0.89	0.55	1.50	M4	6	44	560	2,020	19,860	12,030	0.44
15x24	1.65	1.42	1.12	0.63	1.73	M6	4	130	1,230	4,270	32,910	20,590	0.68
16x24	1.65	1.42	1.12	0.63	1.73			130	1,300	4,270	30,880	20,590	0.66
18x26	1.73	1.50	1.22	0.71	1.85	M6	4	150	1,760	4,950	27,690	19,140	0.71
19x27	1.73	1.50	1.22	0.71	1.89			150	1,850	4,950	26,240	18,410	0.77
20x28	1.73	1.50	1.22	0.71	1.93				1,960		24,940	17,830	0.79
22x32	2.01	1.77	1.50	0.98	2.13	M6	4	150	2,150	4,950	16,240	11,160	0.99
24x34	2.01	1.77	1.50	0.98	2.20				2,350		14,930	10,580	1.06
25x34					2.20		4		2,450	4,950	14,350	10,580	1.10
28x39	2.01	1.77	1.50	0.98	2.40	M6	6	150	4,110	7,420	19,280	13,770	1.15
30x41					2.44		6		4,410	7,420	17,980	13,190	1.17
32x43	2.01	1.77	1.50	0.98	2.56				6,090	9,670	21,750	16,240	1.28
35x47	2.20	1.97	1.69	1.18	2.72	M6	8	150	6,860	9,900	17,110	12,760	1.52
38x50	2.20	1.97	1.69	1.18	2.83				7,450	9,900	15,800	11,890	1.61
40x53	2.20	1.97	1.69	1.18	2.95	M6		150	7,840	9,900	14,930	11,310	1.76
42x55	2.56	2.24	1.93	1.26	3.07	M8	8	360	14,730	18,000	24,650	18,850	1.83
45x59	2.87	2.56	2.24	1.57	3.35	M8		360	16,300	18,450	18,410	14,060	3.09
48x62	3.07	2.76	2.44	1.77	3.43		8		16,890	18,000	14,930	11,600	3.13
50x65	3.07	2.76	2.44	1.77	3.62	M8	10	360	22,640	22,950	18,410	14,210	3.53
55x71	3.27	2.95	2.64	1.97	3.86		10		24,910	22,950	15,080	11,740	4.19
60x77	3.27	2.95	2.64	1.97	4.09	M8		360	27,170	22,950	13,770	10,730	4.52
65x84	3.27	2.95	2.64	1.97	4.37	M8	10	360	29,430	22,950	12,760	9,860	4.74
70x90	3.98	3.58	3.15	2.36	4.69	M10		730	50,340	36,670	15,660	12,180	7.39
75x95	3.98	3.58	3.15	2.36	4.96		10		53,930	36,670	14,640	11,600	7.94
80x100	4.17	3.78	3.35	2.56	5.16	M10	12	730	69,040	43,870	15,220	12,180	8.27
85x106	4.17	3.78	3.35	2.56	5.39		12		73,350	43,870	14,350	11,450	8.93
90x112	4.17	3.78			5.63	M10	15	730	97,090	54,900	16,820	13,480	9.53
95x120	4.17	3.78	3.35	2.56	6.02	M10	15	730	102,480	54,900	15,950	12,610	9.92
100x125	4.49	4.02			6.38	M12	12	1,280	125,650	63,900	17,690	14,210	10.6
110x140			4.49		7.09		12		134,300	62,100	11,310	8,840	13.6
120x155	5.51	5.04	4.53	3.54	7.80	M12	12	1,280	146,510	62,100	10,290	7,970	22.4
130x165			4.53		7.99		16		211,630	82,800	12,760	10,000	26.2

1) These are the maximum tightening torques. They can be reduced to max. 40% of the figures above with T, F_{ax}, P_W and P_N being reduced proportionally.

For stainless steel dimensions and values request table M367697.

KTR 225 (self-centering)



- 1 Multiple bore sizes available per series
- 1 Economical design
- 1 Ease of assembly
- 1 Installation instructions available at www.ktr.com

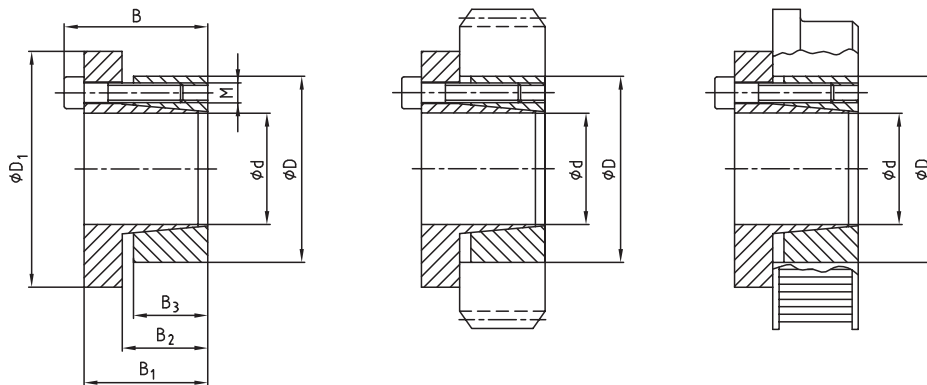

Assembly

Clean and lightly oil the contact surfaces of the shaft and hub bore. Slightly loosen the fasteners and put the clamping unit into the hub bore and shaft. Tighten each fastener evenly in a cross pattern until the front surfaces of the outer and inner rings are flush. Do not exceed the max. tightening torque of the fasteners. The values for T and F_{ax} shown in the table relate to an assembly with a lubricated clamping device. The clamping devices are delivered pre-lubricated. When assembling unlubricated clamping devices, the values shown in the table and the values calculated are different. If you have questions, please contact KTR.

Note: Do not use any oil with molybdenum sulfide or high-pressure lubrication or grease between the contact surfaces of device and hub to shaft.

Disassembly

All fasteners must be removed in an even cross pattern. Insert the fasteners into the backing threads, tighten them in an even cross pattern until the tapered ring is free. For repeatability use oil on the fasteners and threads.

Tolerances, surfaces

Typical turning process is sufficient:
RZ ≤ 630µin

Maximum allowable tolerances:
h8 for the shaft - H8 for the hub

Axial movement

KTR 225: During the tightening of the screws there is no axial movement of the hub towards the shaft.

Concentricity

KTR 225 is **self-centering**. The concentricity of the clamping device is **0.0008 in to 0.0016 in** between the hub and the shaft.

Order form:	KTR 225	28	x	65
	Design	Size of inside diameter		Size of outside diameter

KTR 225 (self-centering) – Technical data

CLAMPEX® – KTR 225													
d x D [mm]	Dimensions ²⁾ [in]					Fasteners DIN EN ISO 4762 - 12.9 $\mu_{total}=0.14$			Transmittable torque or axial force		Surface Pressure on Shaft		Weight [lb]
	B	B ₁	B ₂	B ₃	D ₁	M	z Number	T _A ¹⁾ [lb-in]	T [lb-in]	F _{ax} [lbf]	Shaft P _W [psi]	Hub P _N [psi]	
14x55									1,230	4,500	38,130		1.10
16x55	1.50	1.18	0.87	0.67	2.44	M8	4	360	1,720	5,400	35,380	17,690	1.08
18x55									2,210	6,300	33,060		1.06
19x55	1.50	1.18	0.87	0.67	2.44	M8	4	360	2,460	6,520	32,040	17,690	1.04
20x55									2,700	6,970	31,030		1.01
22x55									3,200	7,420	29,430		0.99
24x55	1.50	1.18	0.87	0.67	2.44	M8	4	360	3,690	7,870	27,980	17,690	0.95
25x55									3,940	8,100	27,260		0.93
28x55									4,680	8,550	25,660		0.86
30x55	1.50	1.18	0.87	0.67	2.44	M8	4	360	5,170	8,770	24,650	17,690	0.82
24x65									4,130	8,770	30,590		1.46
25x65	1.50	1.18	0.87	0.67	2.83	M8	5	360	4,420	9,000	29,870	18,700	1.43
28x65									5,300	9,670	27,980		1.37
30x65									5,880	9,900	26,970		1.32
32x65	1.50	1.18	0.87	0.67	2.83	M8	5	360	6,470	10,350	25,950	18,700	1.28
35x65									7,340	10,570	24,790		1.19
38x65									8,220	11,020	23,780		1.10
40x65	1.50	1.18	0.87	0.67	2.83	M8	5	360	8,800	11,250	23,340	18,700	1.04
30x80									7,940	13,500	30,450		2.38
32x80	1.61	1.30	0.98	0.79	3.46	M8	7	360	8,710	13,950	29,290	18,120	2.32
35x80									9,860	14,400	27,690		2.23
38x80									11,010	14,620	26,390		2.14
40x80	1.61	1.30	0.98	0.79	3.46	M8	7	360	11,780	15,070	25,660	18,120	2.07
42x80									12,540	15,070	24,940		2.01
45x80									13,690	15,520	24,070		1.87
48x80	1.61	1.30	0.98	0.79	3.46	M8	7	360	14,840	15,750	23,340	18,120	1.74
50x80									15,610	15,970	23,050		1.65

1) These are the maximum tightening torques. They can be reduced to max. 40% of the figures above with T, F_{ax}, P_W and P_N being reduced proportionally.

Assembly with belt drive

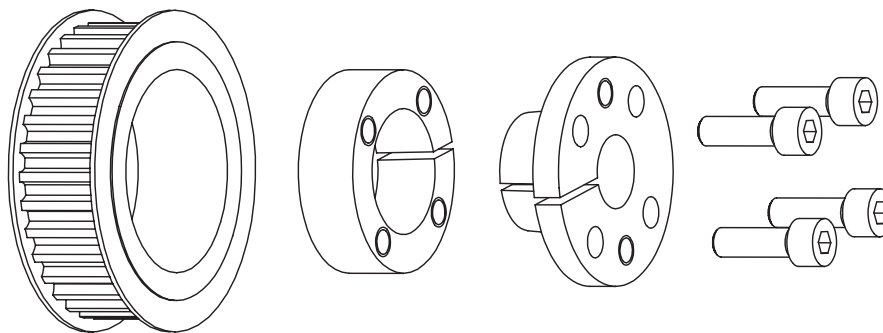

KTR 225 accommodates multiple shaft sizes per series while utilizing only one bore dimension in the pulley.

1) These are the maximum tightening torques. They can be reduced to max. 40% of the figures above with T, F_{ax}, P_W and P_N being reduced proportionally.

Other sizes on request.

KTR 400 (self-centering)



- 1 Clamping device suitable for high transmittable torques
- 1 Ideal for alternating torques
- 1 Typical applications: flywheels, belt drums
- 1 Torque multiplier
 - 1 unit 1 x T
 - 2 units 1.9 x T
 - 3 units 2.7 x T
 - 4 units 3.6 x T
- 1 KTR 402 for shaft Ø 12.6 in to Ø 22.05 in and high torques, request M483041.
- 1 Installation instructions available at www.ktr.com

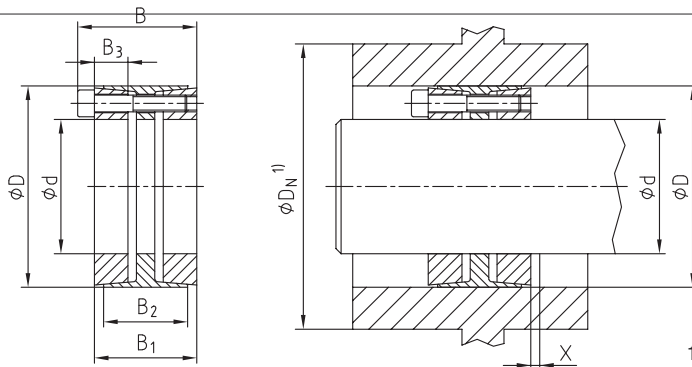

Formula to calculate space x left for disassembly:

$$x = \frac{(B1 - B2)}{2}$$

1) Dimension D_N : To calculate see page 220/221.

Assembly

Clean and lightly oil the contact surfaces of the shaft and hub bore. Slightly loosen the fasteners and put the clamping unit into the hub bore and shaft. Tighten each fastener evenly in a cross pattern until the front surfaces of the outer and inner rings are flush. Do not exceed the max. tightening torque of the fasteners. The values for T and F_{ax} shown in the table relate to an assembly with a lubricated clamping device. The clamping devices are delivered pre-lubricated. When assembling unlubricated clamping devices, the values shown in the table and the values calculated are different. If you have questions, please contact KTR.

Note: Do not use any oil with molybdenum sulfide or high-pressure lubrication or grease between the contact surfaces of device and hub to shaft.

Disassembly

All fasteners must be removed in an even cross pattern. Insert the fasteners into the backing threads, tighten them in an even cross pattern until the front tapered ring is free, then insert the fasteners into the backing threads of the spacer ring in order to free the rear tapered ring.

Note: If the clamping device KTR 400 is reused, please make sure that the pull-off thread of the front taper ring and the spacer ring are aligned in the original position. Slots in the front and of the back pressure ring and the external ring must be flush.

Tolerances, surfaces

Typical turning process is sufficient:

RZ ≤ 630µin

Maximum allowable tolerances:

h8 for the shaft - H8 for the hub

Axial movement

slight axial movement may occur between the hub and the shaft during assembly.

Centering

KTR 225 is **self-centering**. The concentricity of the clamping device is **0.0008 in to 0.0016 in** between the hub and the shaft.

Example of assembly

Conveyor belt drum drive

The following should be adhered to as limiting values for CLAMPEX® clamping devices with bending loads: Angles x on the contact surface of the shaft-clamping device # 6° or maximum shaft bending f_m in the bearing area:

$f_m \# 1 (1/2000 - 1/3000)$.

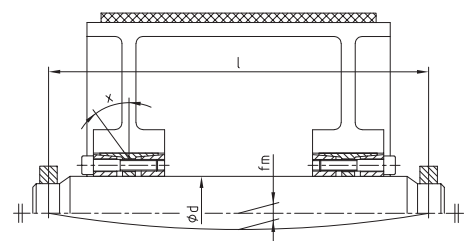

Order form:	KTR 400	100	x	145
	Design	Size of inside diameter		Size of outside diameter

KTR 400 (self-centering) – Technical data

CLAMPEX® – KTR 400																					
d x D [mm]		Dimensions [in]				Standard industrial applications							Applications with components subject to bending and torsion							Weight [lb]	
						Fasteners DIN EN ISO 4762 - 12.9 $\mu_{total}=0.14$			Transmittable torque or axial force		Surface Pressure on Shaft		Fasteners DIN EN ISO 4762 - 12.9 $\mu_{total}=0.14$			Transmittable torque or axial force		Trans- mittable bending moment	Surface Pressure on Shaft		
		B	B ₁	B ₂	B ₃	M	z Number	T _A ¹⁾ [lb-in]	T [lb-in]	F _{ax} [lbf]	Shaft P _W [psi]	Hub P _N [psi]	M	z Number	T _A ¹⁾ [lb-in]	T [lb-in]	F _{ax} [lbf]	Mb perm. [lb-in]	Shaft P _W [psi]		Hub P _N [psi]
24x50						6		6,300		29,720	12,320										
25x50	2.01	1.77	1.61	0.63	M6	6	150	6,560	13,270	28,560	12,320	M6	6	120	4,910	9,900	2,900	32,480	12,610	1.17	
28x55						8		7,350		25,520	11,310		8		5,380	9,670	3,240	29,430	11,740	1.10	
30x55								10,500		31,750	14,930				7,780	13,050	4,060	36,250	15,370	1.04	
32x60	2.01	1.77	1.61	0.63	M6	8	150	11,200	17,770	29,720	13,770	M6	8	120	8,190	12,820	4,330	34,360	14,350	1.70	
35x60								12,250		27,110	13,770				8,780	12,600	4,740	31,750	14,500	1.57	
38x65	2.01				M6	10	150	16,630	22,270	31,320	15,800	M6	10	120	11,600	15,520	6,620	37,260	17,110	2.76	
40x65	2.01	1.77	1.61	0.63	M6	10	150	17,510	22,270	29,720	15,800	M6	10	120	12,040	15,300	6,960	35,810	17,110	2.67	
42x75	2.09				M8	8	360	27,180	32,850	41,900	20,300	M8	8	300	20,160	24,070	7,310	47,560	20,730	2.56	
45x75	2.09	1.77	1.61	0.63				29,110	32,850	39,000	20,300				21,310	24,070	7,840	44,800	21,020	2.38	
48x80	2.76	2.44	2.28	0.91	M8	8	360	31,130	33,070	28,420	13,480	M8	8	300	21,830	23,170	13,220	30,010	14,350	3.20	
50x80	2.76	2.44	2.28	0.91				32,430	33,070	27,260	13,480				20,060	20,470	15,740	28,420	14,060	3.04	
55x85						8		35,670	33,070	24,790	12,760		8		21,310	19,800	17,320	26,390	13,480	3.29	
60x90	2.76	2.44	2.28	0.91	M8	10	360	48,650	41,170	28,420	14,930	M8	10	300	30,500	25,870	18,880	29,430	15,510	3.53	
65x95						10		52,700	41,170	26,240	14,210		10		32,150	25,200	20,460	27,550	14,930	3.75	
70x110						10		90,120	65,470	31,750	16,090		10		58,580	42,520	32,380	32,190	16,380	6.88	
75x115	3.39	2.99	2.76	1.10	M10	10	730	96,560	65,470	29,580	15,510	M10	10	610	61,510	41,620	34,690	30,450	15,950	7.25	
80x120						12		123,590	78,520	33,350	17,690		12		81,420	51,750	37,000	33,490	17,830	7.63	
85x125								131,320	78,520	31,320	17,110				85,080	50,850	39,320	31,900	17,400	8.03	
90x130	3.39	2.99	2.76	1.10	M10	12	730	139,040	78,520	29,580	16,380	M10	12	610	88,580	49,950	41,630	30,450	16,820	8.40	
95x135								146,770	78,520	27,980	15,800				91,890	49,270	43,940	29,140	16,380	8.78	
100x145						12		224,940	114,300	31,030	16,240		12		146,280	74,470	76,880	31,750	16,670	13.5	
110x155	4.33	3.86	3.62	1.38	M12	12	1280	247,430	114,300	28,270	15,220	M12	12	1,060	156,290	72,220	83,590	29,430	15,950	14.6	
120x165						14		314,920	133,420	30,160	16,670		14		203,110	85,950	91,200	31,030	17,250	15.7	
130x180						12		401,240	156,820	27,980	15,370		12		252,270	98,550	135,860	29,140	15,950	22.0	
140x190	5.04	4.49	4.25	1.61	M14	14	2030	504,120	183,150	30,300	16,960	M14	14	1,680	324,990	118,120	146,310	31,170	17,400	23.4	
150x200						16		617,290	209,250	32,330	18,410		16		405,340	137,470	156,760	32,770	18,700	24.8	
160x210	5.04	4.49	4.25	1.61	M14	16	2030	658,440	209,250	30,300	17,540	M14	16	1,680	424,470	134,770	167,220	31,170	17,980	26.3	
170x225	6.38	5.75	5.35	2.05	M16	14	3140	850,780	254,470	27,400	15,800	M16	14	2,610	525,000	157,050	283,760	28,420	16,380	38.9	
180x235	6.38	5.75	5.35	2.05	M16	16	3140	1,029,520	290,700	29,430	17,250	M16	16	2,610	651,360	184,050	300,450	30,300	17,690	40.8	
190x250						16		1,086,710	290,700	27,980	16,240		16		675,680	180,900	317,140	29,000	16,820	47.2	
200x260	6.38	5.75	5.35	2.05	M16	16	3140	1,143,910	290,700	26,530	15,660	M16	16	2,610	698,750	177,520	333,830	27,840	16,380	49.3	
220x285						20		1,572,870	363,600	30,160	17,830		20		1,002,010	231,520	367,210	30,880	18,120	58.6	
240x305	6.38	5.75	5.35	2.05	M16	22	3140	1,887,450	399,820	30,450	18,270	M16	22	2,610	1,205,410	255,370	400,600	31,030	18,700	63.3	
260x325	6.38	5.75	5.35	2.17	M16	22	3140	2,065,800	403,870	26,820	17,690	M16	22	2,610	1,266,480	247,720	452,270	27,980	18,410	68.9	
280x355	7.76	6.97	6.50	2.60	M20	18	6100	2,976,610	540,450	27,840	17,540	M20	18	5,130	1,858,940	337,500	719,690	29,000	18,270	103	
300x375						20		3,543,580	600,520	28,850	18,410		20		2,239,460	379,570	771,090	29,870	19,140	110	
320x405	7.76	6.97	6.50	2.60	M20	21	6100	3,968,820	630,670	28,420	17,980	M20	21	5,130	1,937,890	396,450	822,500	29,430	18,560	133	
340x425						22		4,417,670	660,600	27,980	17,830		22		2,764,900	413,550	873,910	29,140	18,560	141	
360x455						21		5,557,890	785,020	27,260	17,250		21		3,444,540	486,450	1,226,960	28,420	17,980	191	
380x475	8.82	7.95	7.48	2.99	M22	22	8230	6,146,030	822,370	26,970	17,250	M22	22	6,900	3,799,130	508,270	1,295,120	28,270	18,120	201	
400x495						24		7,057,640	897,070	27,980	18,120		24		4,415,750	561,150	1,363,290	29,140	18,850	210	

1) These are the maximum tightening torques. They can be reduced to max. 40% of the figures above with T, F_{ax}, P_W and P_N being reduced proportionally.

Other sizes on request.

KTR 130 and KTR 131 (self-centering)



- 1 Corrosion-protected surface
- 1 Assembly and disassembly by using center nut
- 1 Self-centering
- 1 Shaft diameters from 0.20 in to 1.97 in
- 1 Tolerance h9/H9 for shaft and hub
- 1 Installation instructions available at www.ktr.com

KTR 130

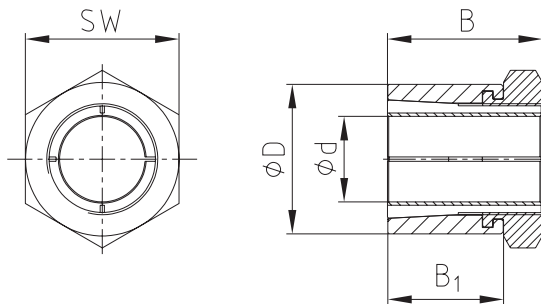

KTR 131

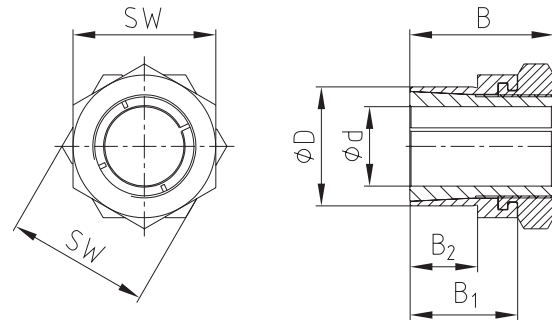

Assembly

Clean and lightly oil the contact surfaces of the shaft and hub bore. Slightly loosen the nut. Put the clamping unit into the hub bore and shaft. Lightly tighten the nut and align the clamping device with the hub. Finish tightening the nut to the required tightening torque T_A listed. The values for T and F_{ax} shown in the table relate to an assembly with a lubricated clamping device. The clamping devices are delivered pre-lubricated. When assembling unlubricated clamping devices, the values shown in the table and the values calculated are different. If you have questions, please contact KTR.

Note: Do not use any oil with molybdenum sulfide or high-pressure lubrication or grease between the contact surfaces of device and hub to shaft.

Disassembly

Loosen the nut until the clamping device can be moved on the shaft. For repeatability use oil on the nut and thread.

Tolerances, surfaces

Typical turning process is sufficient:
 $RZ \leq 630\mu\text{in}$

Maximum allowable tolerances:
h9 for the shaft - H9 for the hub

Axial movement

KTR 130: A slight axial movement may occur between the hub and the shaft during assembly.

Concentricity

KTR 130 is **self-centering**. The concentricity of the clamping device is **0.0008 in to 0.0016 in** between the hub and the shaft.

Order form:	KTR 130	18	x	35
	Design	Size of inside diameter		Size of outside diameter

KTR 130 and KTR 131 (self-centering) – Technical data

CLAMPEX® – KTR 130									
d x D [mm]	Dimensions [in]		Hex nut		Transmittable torque or axial force		Surface Pressure on Shaft		Weight [lb]
	B	B ₁	Width across flats SW	T _A [lb-in]	T [lb-in]	F _{ax} [lbf]	Shaft P _W [psi]	Hub P _N [psi]	
5x14	0.75	0.59	0.55	89	89	900	38,280	13,920	0.04
6x14	0.75	0.59	0.55	89	100	900	31,900	13,920	0.04
8x16	0.87	0.67	0.67	150	200	1,300	25,950	13,190	0.05
9x20				300	380	2,180	35,960	16,240	0.09
10x20	0.94	0.75	0.87	300	430	2,180	32,330	16,240	0.10
12x22				380	570	2,450	29,870	16,960	0.11
14x26					820		25,810		0.18
15x26	1.10	0.87	1.06	570	870	2,990	24,070	14,350	0.17
16x26					930		22,620		0.16
18x35					1,970		32,480		0.43
19x35	1.42	1.06	1.42	1,420	2,070	5,580	30,740	18,120	0.42
20x35					2,190		29,140		0.40
22x42					3,080		28,560		0.75
24x42	1.61	1.18	1.81	2,210	3,370	7,150	26,100	15,950	0.71
25x42					3,510		25,080		0.68
30x47	1.73	1.30	1.97	3,140	5,350	9,090	23,490	15,950	0.82
32x55	2.01	1.50	2.17	4,330	6,760	10,750	24,070	14,790	1.38
35x55	2.01	1.50	2.17	4,330	7,390	10,750	21,890	14,790	1.25
40x62	2.28	1.69	2.56	7,080	11,760	14,960	22,040		1.84
45x65	2.48	1.89	2.56	7,960	14,200	15,970	20,590	14,210	1.89
48x75					19,710		17,540		3.24
50x75	2.87	2.28	2.95	11,410	20,530	20,700	16,820	11,160	3.04

CLAMPEX® – KTR 131										
d x D [mm]	Dimensions [in]			Hex nut/ counter nut		Transmittable torque or axial force		Surface Pressure on Shaft		Weight [lb]
	B	B ₁	B ₂	Width across flats SW	T _A [lb-in]	T [lb-in]	F _{ax} [lbf]	Shaft P _W [psi]	Hub P _N [psi]	
5 x 12						89	900	38,280		0.04
6 x 12	0.75	0.59	0.35	0.55	89	100	900	31,900	17,250	0.03
8 x 14	0.87	0.67	0.43	0.67	150	200	1,305	25,950	17,540	0.05
10 x 18	0.94	0.75	0.47	0.87	300	430	2,183	32,040	18,410	0.10
12 x 20	0.94	0.75	0.47	0.87	380	570	2,453	29,870	18,560	0.10
14 x 24						820		25,810		0.17
15 x 24	1.10	0.87	0.59	1.06	570	870	2,993	24,070	15,510	0.16
16 x 24						930		22,620		0.15
18 x 30						1,970		32,480		0.39
19 x 30	1.42	1.06	0.67	1.42	1,420	2,070	5,580	30,740	21,020	0.39
20 x 30						2,190		29,140		0.36
22 x 38						3,080		28,560		0.74
24 x 38	1.61	1.18	0.79	1.81	2,210	3,370	7,155	26,100	17,690	0.69
25 x 38						3,510		25,080		0.67
30 x 42	1.73	1.30	0.91	1.97	3,140	5,350	9,090	23,490	17,830	0.75
32 x 50	2.01	1.50	1.10	2.17	4,330	6,760	10,755	24,070	16,240	1.21
35 x 50	2.01	1.50	1.10	2.17	4,330	7,390	10,755	21,890	16,240	1.09

KTR 100 (not self-centering)



- 1 Standard internal clamping device
- 1 Fastening of the hub axially
- 1 Torque multiplier

1 unit	1 x T
2 units	1.9 x T
3 units	2.7 x T
4 units	3.6 x T
- 1 Installation instructions available at www.ktr.com

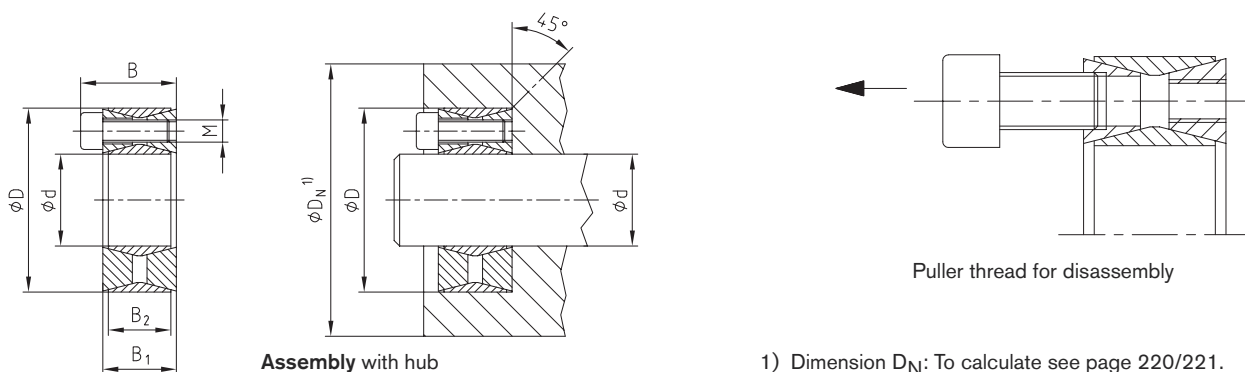

Assembly

Clean and lightly oil the contact surfaces of the shaft and hub bore. Slightly loosen the fasteners and put the clamping unit into the hub bore and shaft. Tighten each fastener evenly in a cross pattern until the front surfaces of the outer and inner rings are flush. Do not exceed the max. tightening torque of the fasteners. The values for T and F_{ax} shown in the table relate to an assembly with a lubricated clamping device. The clamping devices are delivered pre-lubricated. When assembling unlubricated clamping devices, the values shown in the table and the values calculated are different. If you have questions, please contact KTR.

Note: Do not use any oil with molybdenum sulfide or high-pressure lubrication or grease between the contact surfaces of device and hub to shaft.

Disassembly

All fasteners must be removed in an even cross pattern. The clamping device should release automatically. If it does not then slightly strike with a hammer on the loosened fasteners. Then use the puller threads to disassemble device. For repeatability use oil on the fasteners and threads.

Note: The puller threads for disassembly have approx. 3-5 supporting threads.

Tolerances, surfaces

Typical turning process is sufficient:

$RZ \leq 630\mu m$

Maximum allowable tolerances:

h11 for the shaft - H11 for the hub

Axial movement

KTR 100: There is no axial movement between the hub and the shaft during assembly.

Concentricity

KTR 100 is not **self-centering**. The concentricity of the clamping device is dependent on tolerance and length of the counter bore.

Order form:	KTR 100	50	x	80
	Design	Size of inside diameter		Size of outside diameter

KTR 100 (not self-centering) – Technical data

CLAMPEX® – KTR 100											
d x D [mm]	Dimensions [in]			Fasteners DIN EN ISO 4762 - 12.9 $\mu_{total}=0.14$			Transmittable torque or axial force		Surface pressure on shaft		Weight [~lb]
	B	B ₁	B ₂	M	z Number	T _A ¹⁾ [lb-in]	T [lb-in]	F _{ax} [lbf]	Shaft P _W [psi]	Hub P _N [psi]	
18 x 47	1.02	0.79	0.67	M6	8	130	2,120	6,070	41,900	16,090	0.53
19 x 47							2,240		39,730		
20 x 47	1.02	0.79	0.67	M6	8	130	2,360	6,070	37,700	16,090	0.51
22 x 47							2,600		34,360		
24 x 50	1.02	0.79	0.67	M6	12	130	2,830	9,000	31,460	15,080	0.57
25 x 50							2,950		30,160		
28 x 55	1.02	0.79	0.67	M6	12	130	4,950	9,000	40,450	20,590	0.66
30 x 55							5,310		37,700		
32 x 60	1.02	0.79	0.67	M6	12	130	5,670	9,000	35,380	18,850	0.75
35 x 60							6,200		32,330		
38 x 65	1.02	0.79	0.67	M6	15	130	8,410	11,250	37,260	21,750	0.79
40 x 65							8,850		35,380		
42 x 75	1.26	0.94	0.79	M8	12	320	13,320	16,200	41,030	23,050	1.32
45 x 75	1.26	0.94	0.79	M8	12	320	14,280	16,200	38,280	23,050	1.26
48 x 80	1.26	0.94	0.79	M8	12	320	15,230	16,200	35,960	21,600	1.32
50 x 80							15,860		34,510		
55 x 85	1.26	0.94	0.79	M8	15	320	21,810	20,250	39,150	25,370	1.39
60 x 90							23,800		35,960		
65 x 95	1.26	0.94	0.79	M8	15	320	25,790	20,250	33,200	22,620	1.61
70 x 110	1.50	1.10	0.94	M10	15	610	44,180	32,170	40,890	25,950	2.78
75 x 115	1.50	1.10	0.94	M10	15	610	47,340	32,170	38,130	24,790	2.93
80 x 120							50,490		35,670		
85 x 125	1.50	1.10	0.94	M10	15	610	53,920	32,170	33,640	22,910	3.29
90 x 130							56,800		31,750		
95 x 135	1.50	1.10	0.94	M10	18	610	71,950	38,470	36,100	25,370	3.57
100 x 145	1.73	1.26	1.02	M12	15	1,120	96,300	49,050	40,310	27,690	4.43
110 x 155	1.73	1.26	1.02	M12	15	1,120	105,930	49,050	36,540	25,950	4.74
120 x 165	1.73	1.26	1.02	M12	16	1,120	123,260	52,200	35,810	25,950	5.18
130 x 180	1.97	1.50	1.34	M12	20	1,120	166,920	65,250	31,610	22,760	7.74
140 x 190	1.97	1.50	1.34	M12	22	1,120	197,740	78,300	32,190	23,780	8.49
150 x 200							231,120		32,770		
160 x 210	1.97	1.50	1.34	M12	24	1,120	267,070	84,820	33,350	25,370	9.48
170 x 225							316,060		31,320		
180 x 235	2.28	1.73	1.50	M14	24	1,720	365,080	103,050	32,190	24,650	13.3
190 x 250	2.60	2.05	1.81	M14	28	1,720	449,590	120,370	29,430	22,330	18.2
200 x 260	2.60	2.05	1.81	M14	30	1,720	507,060	128,920	29,870	23,050	19.1
220 x 285	2.83	2.20	1.97	M16	26	2,650	662,390	153,000	29,720	22,910	24.7
240 x 305	2.83	2.20	1.97	M16	30	2,650	833,780	176,620	31,460	24,790	26.9
260 x 325	2.83	2.20	1.97	M16	34	2,650	1,023,690	200,250	32,910	26,390	29.1
280 x 355	3.43	2.60	2.36	M18	32	3,620	1,232,590	223,870	28,420	22,470	42.3
300 x 375	3.43	2.60	2.36	M18	36	3,620	1,485,720	251,770	29,870	23,920	45.2
320 x 405	3.98	3.07	2.83	M20	26	5,220	2,125,920	337,720	31,320	24,790	65.3
340 x 425	3.98	3.07	2.83	M20	36	5,220	2,258,780	337,720	29,430	23,630	68.6
360 x 455	4.57	3.54	3.31	M22	36	6,990	2,904,770	410,170	29,000	22,910	93.1
380 x 475	4.57	3.54	3.31	M22	36	6,990	3,066,150	410,170	27,400	22,040	97.0
400 x 495							3,227,520		26,100		
420 x 515	4.57	3.54	3.31	M22	40	6,990	3,292,150	398,470	28,420	23,200	110
440 x 545							4,016,550		27,260		
460 x 565	5.12	4.02	3.78	M24	40	8,850	4,138,260	457,420	26,100	21,170	149
480 x 585							4,534,100		26,240		
500 x 605	5.12	4.02	3.78	M24	44	8,850	4,947,930	503,100	26,390	21,750	160
520 x 630							5,340,190		25,950		
540 x 650	5.12	4.02	3.78	M24	45	8,850	5,545,580	522,220	24,940	20,730	181
560 x 670							6,045,470		25,660		
580 x 690	5.12	4.02	3.78	M24	50	8,850	6,522,270	571,720	25,810	21,750	194
600 x 710							6,846,390		24,940		

1) The tightening torques can be increased by max. 1.1 times or reduced to 0.6 times of the values T, F_{ax} and P_W, P_N being reduced proportionally.

Other sizes on request.

KTR 150 (not self-centering)



- 1 Clamping device for compact bore / shaft mounting dimensions
- 1 Torque multiplied by stacking clamping devices in series
- 1 Installation instructions available at www.ktr.com

Before tightening fasteners

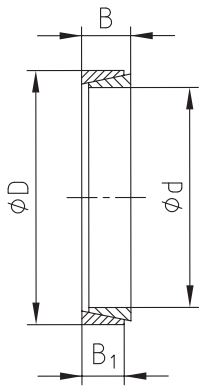

Assembly 1

Clamping onto hub

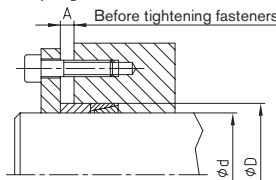

Assembly 2

Clamping to shaft

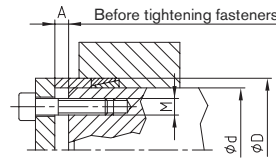

Up to 4 clamping devices can be used in a series.

The torques increase as follows:

- 1 unit = torque catalog x 1
- 2 units = torque catalog x 1.55
- 3 units = torque catalog x 1.85
- 4 units = torque catalog x 2.02

Recommended pressure flanges*
(see table below for dimensions)

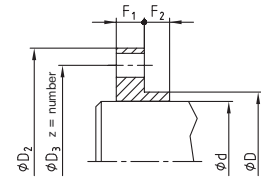
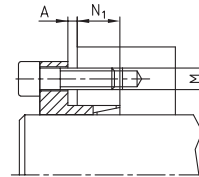

Assembly

Clean and lightly oil the contact surfaces of the shaft and hub bore. Insert the clamping device, distance ring and clamping flange, tighten each fastener evenly in a cross pattern until the tightening torque of the fasteners are achieved. Do not exceed the max. tightening torque of the fasteners. The values for T and F_{ax} shown in the table relate to an assembly with a lubricated clamping device. The clamping devices are delivered pre-lubricated. When assembling unlubricated clamping devices, the values shown in the table and the values calculated are different. If you have questions, please contact KTR.

Note: Do not use any oil with molybdenum sulfide or high-pressure lubrication or grease between the contact surfaces of device and hub to shaft.

Disassembly

All fasteners must be removed in an even cross pattern. The clamping device should release automatically.

Tolerances, surfaces

One accurate turning process is sufficient:

$RZ \leq 236\mu\text{in}$

Maximum allowable tolerances:

Shaft h6 - hub H7 (# \varnothing 1.500")

Shaft h8 - hub H8 (> \varnothing 1.500")

Recommended dimensions of pressure flange* for 1 to 4 clamping elements KTR 150																																	
$d^H \times D_{g7}$	9.1 x 12	10.1 x 13	12.1 x 15	13.1 x 16	14.1 x 18	15.1 x 19	16.2 x 20	17.2 x 21	18.2 x 22	19.2 x 24	20.2 x 25	22.2 x 26	24.2 x 28	25.2 x 30	28.2 x 32	30.2 x 35	32.2 x 36	35.2 x 40	36.2 x 42	38.2 x 44	40.2 x 45	42.2 x 48	45.2 x 52	48.2 x 55	50.2 x 57	55.2 x 62	56.2 x 64	60.2 x 68	63.2 x 71	65.2 x 73	70.2 x 79	71.2 x 80	75.2 x 84
D_2	1.42	1.46	1.54	1.57	1.73	1.77	1.81	1.85	1.89	2.05	2.09	2.13	2.20	2.28	2.36	2.48	2.52	2.68	2.76	2.83	3.07	3.19	3.35	3.46	3.54	3.74	4.02	4.17	4.29	4.37	4.61	4.65	4.80
D_3	1.10	1.14	1.22	1.26	1.38	1.42	1.46	1.50	1.54	1.65	1.69	1.73	1.77	1.89	1.97	2.09	2.13	2.28	2.36	2.44	2.56	2.68	2.83	2.95	3.03	3.23	3.39	3.54	3.66	3.74	3.98	4.02	4.17
M	M4	M4	M4	M4	M5	M5	M5	M5	M5	M6	M6	M6	M6	M6	M6	M6	M6	M6	M6	M6	M8	M8	M8	M8	M8	M8	M10	M10	M10	M10	M10	M10	M10
z	4	4	4	4	4	4	4	4	4	4	4	4	4	4	4	4	5	6	6	6	6	6	8	8	8	8	8	6	6	6	8	8	8
Tightening torque [lb-in]	26	26	26	26	53	53	53	53	53	89	89	89	89	89	89	89	89	89	89	89	221	221	221	221	221	221	434	434	434	434	434	434	434
F_1	0.22	0.22	0.22	0.22	0.28	0.28	0.28	0.28	0.28	0.31	0.31	0.31	0.31	0.31	0.31	0.31	0.31	0.31	0.31	0.31	0.41	0.41	0.41	0.41	0.41	0.41	0.51	0.51	0.51	0.51	0.51	0.51	0.51
F_2	0.28	0.28	0.28	0.28	0.33	0.33	0.33	0.33	0.33	0.33	0.33	0.33	0.33	0.33	0.33	0.33	0.33	0.33	0.33	0.37	0.37	0.37	0.37	0.37	0.37	0.41	0.41	0.41	0.41	0.41	0.41	0.41	0.41
N_1	The counterbore depth results from the number of clamping sets (max. 4 - offset) and the dimensions = $F_2 - A$.																																

* Part supplied by customer

Order form:	KTR 150	60	x	68
	Design	Size of inside diameter		Size of outside diameter

KTR 150 (not self-centering) – Technical data

CLAMPEX® – KTR 150 ** Design with slit															Other sizes on request.	
d x D [mm]	Dimensions [in]		Distance dimension A [in]				Necessary clamping force for fasteners $m_{total} = 0.14$			Transmittable torque or axial force		Surface pressure on shaft		Weight [lb]		
	B	B ₁	Clamping element				P _O [lbf]	P _S [lbf]	P _A = P _O + P _S [lbf]	T [lb-in]	F _{ax} [lbf]	Shaft P _W [psi]	Hub P _N [psi]			
			1	2	3	4										
6 x 9							**	670	670	18	150	11,600	7,680	0.0026		
7 x 10	0.18	0.15	0.10	0.10	0.12	0.16		1,190	1,190	35	260	17,540	12,320	0.0031		
8 x 11							**	1,260	1,260	44	280	16,240	11,890	0.0033		
9 x 12	0.25	0.21	0.14	0.14	0.18	0.22	1,780	1,490	3,280	62	330	17,250	12,900	0.0037		
10 x 13							1,580	2,010	3,600	89	450	20,730	15,950	0.0040		
12 x 15	0.18	0.15	0.10	0.10	0.12	0.16	1,750	1,840	3,600	97	400	15,950	12,760	0.0046		
13 x 16	0.18	0.15	0.10	0.10	0.12	0.16	1,570	2,180	3,750	120	490	17,400	14,060	0.0051		
14 x 18	0.25	0.21	0.14	0.14	0.18	0.22	2,690	3,150	5,850	190	690	16,240	12,610	0.0108		
15 x 19							2,720	3,350	6,070	220	740	16,090	12,760	0.0117		
16 x 20	0.25	0.21	0.14	0.14	0.18	0.22	2,800	3,260	6,070	230	720	14,790	13,190	0.0121		
17 x 21							2,620	3,780	6,410	280	920	17,400	13,050	0.0128		
18 x 22							3,290	4,130		320	830	14,790	13,630	0.0135		
19 x 24	0.25	0.21	0.14	0.14	0.18	0.22	3,190	4,230	7,420	350	940	16,090	12,760	0.0172		
20 x 25							3,000	4,420		380	990	15,950	12,760	0.0181		
22 x 26							3,080	4,560	7,650	440	1,010	14,930	12,610	0.0159		
24 x 28	0.25	0.21	0.14	0.14	0.18	0.22	1,950	5,690	7,650	600	1,280	17,110	14,640	0.0176		
25 x 30							2,290	6,030	8,320	660	1,350	17,400	14,500	0.0221		
28 x 32							2,530	6,460		790	1,440	16,670	14,640	0.0198		
30 x 35	0.25	0.21	0.14	0.14	0.18	0.22	2,290	6,700	9,000	880	1,500	16,090	13,770	0.0265		
32 x 36							1,450	7,540		1,060	1,680	16,960	15,080	0.0221		
35 x 40							2,050	9,190	11,250	1,410	2,040	16,670	14,640	0.0375		
36 x 42	0.28	0.24	0.14	0.14	0.18	0.22	2,900	9,830	12,730	1,550	2,200	17,400	14,930	0.0441		
38 x 44							3,440	10,050	13,500	1,680	2,250	16,820	14,500	0.0463		
40 x 45	0.31	0.26					4,180	11,560	15,750	2,030	2,580	16,820	14,930	0.0507		
42 x 48	0.31	0.26	0.14	0.18	0.22	0.26	3,300	12,440	15,750	2,300	2,790	17,110	15,080	0.0617		
45 x 52	0.39	0.34					7,320	17,420	24,750	3,450	3,890	17,250	14,930	0.0926		
48 x 55							6,730	18,010	24,750	3,800	4,020	16,670	14,500	0.0992		
50 x 57	0.39	0.34	0.14	0.18	0.22	0.26	5,840	18,900	24,750	4,150	4,230	16,820	14,790	0.1036		
55 x 62							5,790	21,200	27,000	5,130	4,740	17,110	15,220	0.1103		
56 x 64							7,470	26,490	33,970	6,530	5,940	17,400	15,220	0.1477		
60 x 68	0.47	0.41	0.14	0.18	0.22	0.28	7,840	28,150	36,000	7,430	6,300	17,250	15,220	0.1588		
63 x 71							6,860	29,810	36,670	8,260	6,680	17,400	15,510	0.1698		
65 x 73	0.47	0.41		0.18	0.22	0.28	5,060	30,930	36,000	8,850	6,930	17,540	15,660	0.1742		
70 x 79	0.55	0.48	0.14	0.20	0.26	0.30	7,650	37,340	45,000	11,500	8,340	16,670	14,790	0.2426		
71 x 80	0.55	0.48		0.20	0.26	0.30	8,100	39,360	47,470	12,300	8,820	17,400	15,370	0.2646		
75 x 84	0.55	0.48	0.14	0.20	0.26	0.30	9,280	40,210	49,500	13,270	9,000	16,820	15,080	0.2867		
80 x 91	0.67	0.59	0.16	0.24	0.26	0.31	14,710	52,780	67,500	18,580	11,810	16,820	14,790	0.4190		
85 x 96	0.67	0.59	0.16	0.24		0.31	12,240	57,950	70,200	21,680	12,960	17,400	15,370	0.4410		
90 x 101	0.67	0.59	0.16		0.26	0.31	11,670	60,320	72,000	23,890	13,500	17,110	15,220	0.4851		
95 x 106	0.67	0.59	0.16	0.24	0.26	0.31	11,730	64,760	76,500	27,080	14,490	17,400	15,510	0.5072		
100 x 114	0.83	0.74	0.20		0.28	0.35	14,540	84,450	99,000	37,170	18,900	17,250	15,220	0.8379		
110 x 124	0.83	0.74		0.24	0.28	0.35	22,640	78,600	101,250	38,050	17,590	14,640	12,900	0.9041		
120 x 134	0.83	0.74	0.20	0.24	0.28	0.35	18,040	85,450	103,500	45,140	19,120	14,500	13,050	0.9923		
130 x 148	1.10	1.00		0.28	0.35	0.43	20,960	125,280	146,250	71,690	28,030	14,640	12,760	1.8743		
140 x 158							20,240	135,000	155,250	83,190	30,210	14,640	12,900	2.0066		
150 x 168	1.10	1.00	0.24	0.28	0.35	0.43	14,540	147,450	162,000	97,360	33,000	14,930	13,340	2.1389		
160 x 178							18,060	174,300	192,370	122,760	39,010	16,530	14,790	2.2491		
170 x 191	1.30	1.18			0.39	0.47	28,830	219,110	247,950	163,960	49,020	16,380	14,640	3.3075		
180 x 201	1.30	1.18			0.39	0.47	32,060	237,930	270,000	188,520	53,250	16,820	15,080	3.4839		
190 x 211	1.30	1.18	0.28	0.35	0.39	0.47	25,140	256,100	281,250	214,190	57,300	17,250	15,510	3.7044		
200 x 224	1.50	1.37			0.43	0.51	41,050	316,690	357,750	278,800	70,870	17,400	15,510	5.1156		
210 x 234	1.50	1.37		0.35	0.43	0.51	22,560	335,180	357,750	307,660	74,490	17,540	15,800	5.4023		
220 x 244	1.50	1.37	0.28	0.35	0.43	0.51	26,520	349,220	375,750	335,810	77,600	17,400	15,800	5.4905		
230 x 257	1.69	1.56		0.39	0.47	0.55	38,000	416,490	454,500	418,710	92,670	17,540	15,660	7.4529		
240 x 267	1.69	1.56			0.47	0.55	36,150	434,090	470,250	455,370	96,450		15,800	7.7616		
250 x 280	1.89	1.73	0.28	0.39	0.47	0.63	42,970	503,770	546,750	462,420	94,050	17,540	15,660	10.319		
260 x 290	1.89	1.73			0.51	0.63	41,060	523,910	564,970	500,130	97,800		15,660	10.628		
270 x 300	1.89	1.73		0.39	0.51	0.63	40,050	544,950	585,000	540,220	101,720		15,800	10.893		
280 x 313	2.09	1.93	0.28	0.43	0.55	0.67	46,750	628,240	675,000	645,860	117,270	17,540	15,660	13.825		
290 x 323	2.09	1.93		0.43	0.55	0.67	49,650	650,090	699,750	688,070	120,620		15,660	14.333		
300 x 333	2.09	1.93	0.28	0.43	0.55	0.67	48,370	672,750	721,120	736,610	124,830		15,800	14.774		
320 x 360	2.56	2.32	0.39	0.59	0.79	0.98	65,700	865,800	931,500	1,011,190	160,650	17,540	15,660	24.035		
340 x 380	2.56	2.32	0.39	0.59	0.79	0.98	61,870	919,120	981,000	1,140,560	170,550		15,660	25.358		
360 x 400							58,500	972,000	1,030,500	1,250,570	180,360		15,800	26.901		
380 x 420	2.56	2.32	0.39	0.59	0.79	0.98	60,750	1,028,250	1,089,000	1,426,090	190,800	17,540	15,800	28.224		
400 x 440							58,500	1,080,000	1,138,500	1,576,690	200,400		15,950	29.768		

KTR 200 with torsionally flexible ROTEX® coupling

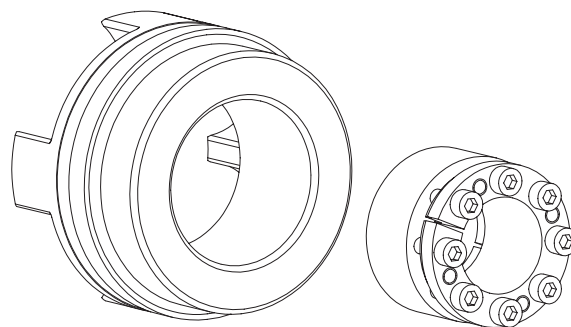
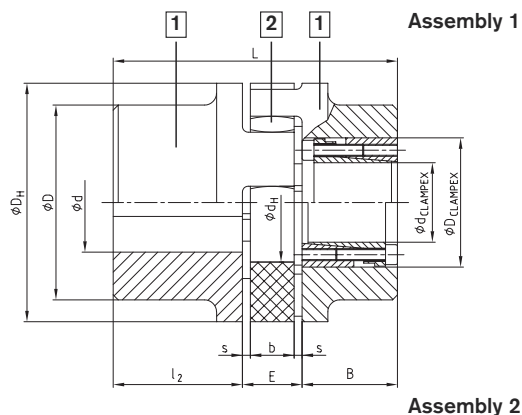

Assembly 2

KTR 200 with torsionally flexible ROTEX® coupling															
ROTEX® size	Pilot bore øD [in]	Hub material	Dimensions of CLAMPEX® KTR 200 [in]					Dimensions of ROTEX® coupling [in]							
			Maximum KTR Clamping d x D [mm]	Transmittable torque or axial force		B	l ₁	E	s	b	D _H	D	D ₁	d _H	L
				T [lb-in]	F _{ax} [lbf]										
42	x	Steel part 1	30x55	6,800	11,470	1.89	1.97	1.02	0.12	0.79	3.74	-	3.74	1.81	
48	x		35x60	10,590	15,300	1.89	2.20	1.10	0.14	0.83	4.13	-	4.13	2.01	
55	x		45x75	18,870	21,370	2.32	2.56	1.18	0.16	0.87	4.72	-	4.72	2.36	
65	x		45x75	18,870	21,370	2.32	2.95	1.38	0.18	1.02	5.31	4.53	-	2.68	
75	x		50x80	27,960	28,350	2.32	3.35	1.57	0.20	1.18	6.30	5.31	-	3.15	
90	x		65x95	36,350	28,350	2.32	3.94	1.77	0.22	1.34	7.87	6.30	-	3.94	
100	1.750	GGG40 part 1	65x95	36,350	28,350	2.32	4.33	1.97	0.24	1.50	8.86	7.09	-	4.45	
110	2.313		70x110	62,160	45,220	2.76	4.72	2.17	0.26	1.65	10.04	7.87	-	5.00	
125	2.313		80x120	71,030	45,220	2.76	5.51	2.36	0.28	1.81	11.42	9.06	-	5.79	
140	2.188		95x135	100,660	53,770	2.60	6.10	2.56	0.30	1.97	12.60	10.04	-	6.50	
160	3.063		110x155	142,210	65,700	3.15	6.89	2.95	0.35	2.24	14.57	11.42	-	7.48	
180	3.125		120x135	193,920	82,120	3.15	7.68	3.35	0.41	2.52	16.54	12.80	-	8.66	

CLAMPEX® – KTR 200																	
d x D [mm]	B [in]	Transmittable torque or axial force		Fasteners DIN EN ISO 4762 12.9		d x D [mm]	B [in]	Transmittable torque or axial force		Fasteners DIN EN ISO 4762 12.9		d x D [mm]	B [in]	Transmittable torque or axial force		Fasteners DIN EN ISO 4762 12.9	
				z x M	T _A [lb-in]					z x M	T _A [lb-in]					z x M	T _A [lb-in]
		T [lb-in]	F _{ax} [lbf]	T [lb-in]	F _{ax} [lbf]	T [lb-in]	F _{ax} [lbf]	T [lb-in]	F _{ax} [lbf]								
20 x 47	1.89	4,540	11,470	6 x M6	150	38x65	1.89	11,490	15,300	8 x M6	150	65x95	2.32	36,350	28,350	8xM8	360
22 x 47	1.89	4,990	11,470	6 x M6	150	40x65	1.89	12,100	15,300	8 x M6	150	70x110	2.76	62,160	45,220	8xM10	730
24 x 50	1.89	5,450	11,470	6 x M6	150	42x75	2.32	17,610	21,370	8 x M6	360	75x115	2.76	66,590	45,220	8xM10	730
25 x 50	1.89	5,670	11,470	6 x M6	150	45x75	2.32	18,870	21,370	8 x M6	360	80x120	2.76	71,030	45,220	8xM10	730
28 x 55	1.89	6,350	11,470	6 x M6	150	48x80	2.32	26,840	28,350	8 x M6	360	85x125	2.76	94,340	56,470	10xM10	730
30 x 55	1.89	6,800	11,470	6 x M6	150	50x80	2.32	27,960	28,350	8 x M6	360	90x130	2.76	99,890	56,470	10xM10	730
32 x 60	1.89	9,680	15,300	6 x M6	150	55x85	2.32	30,750	28,350	8 x M6	360	95x135	2.60	100,660	53,770	10xM10	730
35 x 60	1.89	10,590	15,300	6 x M6	150	60x90	2.32	33,550	28,350	8 x M6	360	Further details see page 201					

Other coupling combination

RADEX® -N NANA 1 with external clamping device KTR 620 and KTR 603

KTR 620

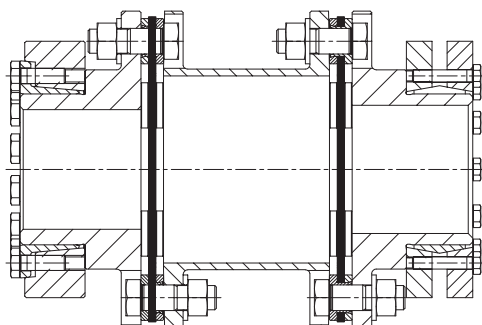

KTR 603

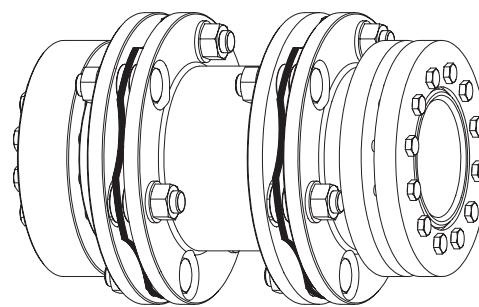

Details for the external clamping device KTR 620 and KTR 603 are on page 192-197.

Available upon request

SPH Clamping sleeve



Self-centering

- 1 Fast assembly and disassembly using one nut
- 1 Suitable for compact hub dimensions
- 1 Typical applications: sprockets, pulleys that are mounted to the shaft end

KTR 401



Self-centering, short design

- 1 Clamping device for large loads
- 1 Suitable for vibratory torques
- 1 Typical applications: flywheels, belt drums
- 1 Shorter than the KTR 400
- 1 Request table **M367699**

KTR 125 and KTR 125.1



KTR 125

Not self-centering,
Short design

- 1 Clamping device for lower torque applications
- 1 Easy to assemble
- 1 Request table **M367700**

KTR 125.1

Self-centering,
Long design

KTR 700



Rigid coupling

- 1 Rigid, zero-backlash torque transmission
- 1 Well-aligned, bending and torsionally stiff shaft connection
- 1 Shaft misalignment cannot be compensated
- 1 Request table **M380931**

Calculation

For properly working CLAMPEX® keyless clamping devices the following design parameters should be taken into account. Please contact us if you have tolerances different from the table below.

CLAMPEX® – Tolerance, Surface Roughness and Concentricity						
Design	d [in]	d _w [in]	Shaft diameter tolerance	Hub bore tolerance	Surface roughness [μ in]	Concentricity (applies for the clamping unit only)
KTR 250	-	-	h8	H8	Rz ≤ 630	0.0008 - 0.0016
KTR 200	-	-	h8	H8	Rz ≤ 630	0.0008 - 0.0016
KTR 201	-	-	h8	H8	Rz ≤ 630	0.0008 - 0.0016
KTR 203	-	-	h8	H8	Rz ≤ 630	0.0008 - 0.0016
KTR 206	-	-	h8	H8	Rz ≤ 630	0.0008 - 0.0016
KTR 225	-	-	h8	H8	Rz ≤ 630	0.0008 - 0.0016
KTR 100	-	-	h11	H11	Rz ≤ 630	1)
KTR 105	-	-	h9	H9	Rz ≤ 630	0.0008 - 0.0016
KTR 150	up to 1.50	-	h6	H7	Rz ≤ 236	1)
KTR 150	above 1.50	-	h8	H8	Rz ≤ 236	1)
KTR 400	-	-	h8	H8	Rz ≤ 630	0.0008 - 0.0016
KTR 620	-	0.51 - 5.91 > 6.30	H7/h6 > H7/g6	H7/f7	Rz ≤ 630	0.0008 - 0.0016
KTR 603	-	0.71 - 1.18	j6	H6	Rz ≤ 630	0.0008 - 0.0016
KTR 603	-	1.22 - 1.97	h6	H6	Rz ≤ 630	0.0008 - 0.0016
KTR 603	-	2.01 - 3.15	g6	H6	Rz ≤ 630	0.0008 - 0.0016
KTR 603	-	3.19 - 19.69	g6	H7	Rz ≤ 630	0.0008 - 0.0016

1) Concentricity dependent on the alignment of the hub or shafts or the drive component and accuracy of assembly, respectively.

Fatigue strength and shape stability of components under torsional loading and bending

The stress formula σ_k , for the clamping devices, is calculated similar to those of hydraulic fittings. Please contact KTR for the calculation. The stress concentration is dependent upon the load, the material and the clamping design. Stress concentration factor provided upon request.

Resulting torque T_R

The transmittable torque $T \approx T_R$ always needs to exceed the highest peak torque T_B which may arise in the frictional connection. The peak torque arising during the acceleration of electric motors must be considered.

$$T \approx TR \quad \& \quad \sqrt{T_B^2 + \left[\frac{F_a \cdot d}{2} \right]^2} \quad [\text{lb-in}]$$

Transmittable axial force F_{ax}

The maximum transmittable axial force F_{ax} which is listed in the tables is reduced accordingly to torque transmission.

$$F_{ax} = \frac{2 \cdot T}{d} \quad [\text{lbf}]$$

Calculation of the outside diameter of the hub D_N

The required outside diameter of the hub D_N depends on the cross section of the hub, the shape of the hub and the yield strength of the hub material. Use the values in the table on page 221 to assist in calculating D_N .

Example:

Shaft diameter $d = 50 \text{ mm}$

Hub material: GGG 40

Apparent yield point of material

$0.2 = 36,250 \text{ psi}$

Selected: CLAMPEX® clamping set KTR 100

with $d \times D = 50 \text{ mm} \times 80 \text{ mm} (1.97" \times 3.15")$ and $PN = 21610 \text{ psi}$ pg. 213

_ approximate value from table on page 219: $PN = 21,755 \text{ psi}$

selected design see page 219. $C = 0.8$ (value C of hub shape)

_ figure as per table 1.69

_ $D_N = D \times 1.69 = 3.15" \times 1.69 = 5.32"$

Outside diameters of hubs which cannot be calculated based on the table are calculated with the following:

$$D_N \geq D \cdot \sqrt{\frac{\sigma_{N0,2} + P_N \cdot C}{\sigma_{N0,2} - P_N \cdot C}} \quad [\text{in}]$$

Pressure on the inside diameter of hub

$$\sigma_{tiN} \approx P_N \frac{(1 + C_N^2)}{(1 - C_N^2)} \cdot C \quad [\text{psi}]$$

For clamping connections with hollow shafts the required inside diameter of the hollow shaft d_{iw} is calculated with the following:

$$d_{iw} \leq d \cdot \sqrt{\frac{\sigma_{W0,2} - 2 \cdot P_W \cdot 0,8}{\sigma_{W0,2}}} \quad [\text{in}]$$

Pressure on the inside diameter of hollow shaft

$$\sigma_{tiW} \approx \frac{2 \cdot P_W}{(C_W^2 - 1)} \quad [\text{psi}]$$

$\sigma_{N0,2}$ = Apparent yield point of the hub material [psi]
 C = Value C of hub shape (see picture on page 221)
 P_N = Perm. surface pressure of clamping device/hub [psi]
 D = Outside diameter of the clamping device [in]
 T = Transmittable torque [lb-in]
 T_R = Resulting transmittable torque [lb-in]
 T_B = Operating torque to be transmitted [lb-in]
 L/L_1 = Hub length [in]

$\sigma_{W0,2}$ = Apparent yield point of the shaft material [psi]
 P_W = Perm. surface pressure of clamping device/shaft [psi]
 d = Inside diameter of the clamping set [in]
 C_W = d_{iw} / d
 C_N = D / D_N
 F_a = Axial force arising during operation [lb-in]
 F_{ax} = Maximum transmittable axial force [lb-in]
 F_V = Prestressed force [lb-in]

Calculation of hubs

Table of fasteners						
Dimension M	Prestressed force F_V and tightening torque T_A with $\mu_{total} = 0.14$					
	Prestressed force F_V [lbf]			Tightening torque T_A [lb-in]		
	8.8	10.9	12.9	8.8	10.9	12.9
M3	490	690	830	12	17	20
M4	870	1,220	1,470	26	36	43
M5	1,420	2,010	2,400	53	75	89
M6	2,020	2,830	3,390	89	120	150
M8	3,710	5,220	6,270	220	300	360
M10	5,890	8,300	9,960	430	610	730
M12	8,610	12,150	14,510	760	1,060	1,280
M14	11,810	16,650	19,910	1,190	1,680	2,030
M16	16,420	22,950	27,670	1,850	2,610	3,140
M18	19,800	27,900	33,300	2,560	3,580	4,290
M20	25,650	36,000	43,200	3,620	5,130	6,100
M22	31,720	44,770	53,770	4,860	6,900	8,230
M24	36,900	51,750	62,100	6,280	8,850	10,620
M27	48,370	67,950	81,670	9,290	13,270	15,930
M30	58,950	82,800	99,450	12,830	17,700	21,240

Mounting conditions of clamping device

Value C of hub shape

C = 0,6

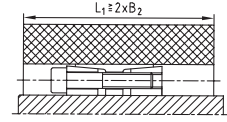
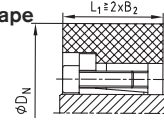

C = 0,8

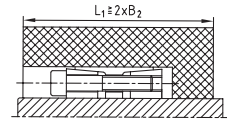
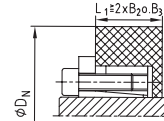

C = 1

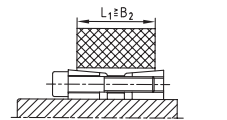
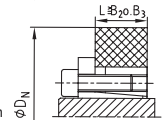

$L/L_1 \hat{=}$ Hub length

$B_2/B_3 \hat{=}$ Clamping set length

Selection table for the calculation of the required outside diameter of hub D_N

Surface pressure on shaft		Average yield point of material σ 0.2 in psi (more accurate stiffness data, depending on the diameter, as per details supplied by the manufacturer)										
		150	180	200	220	250	270	300	350	400	450	600
PN [psi]	Hub form C-value	Hub materials										
		GG 20	GG 25 GS 38	GG 30 GTS 35	GS 45 ST 37-2	GGG 40 GS 52 AlCuMgPb	ST 50-2 C 35	GGG 50 GS 60 ST 52-3	GGG 60 GS 62 C 45	GGG 70 GS 70 C 60	Tempered steel	Tempered steel
8,700	C=0.6	1.28	1.25	1.20	1.18	1.15	1.14	1.12	1.10	1.09	1.08	1.06
	C=0.8	1.39	1.30	1.24	1.23	1.22	1.20	1.18	1.15	1.12	1.11	1.08
	C=1	1.52	1.42	1.36	1.32	1.28	1.25	1.22	1.18	1.16	1.14	1.10
9,420	C=0.6	1.30	1.25	1.22	1.20	1.18	1.15	1.13	1.11	1.10	1.09	1.07
	C=0.8	1.44	1.35	1.30	1.28	1.24	1.22	1.20	1.16	1.14	1.12	1.09
	C=1	1.60	1.45	1.40	1.35	1.30	1.28	1.24	1.20	1.18	1.16	1.12
10,150	C=0.6	1.34	1.26	1.24	1.22	1.18	1.16	1.15	1.12	1.11	1.10	1.07
	C=0.8	1.48	1.38	1.34	1.30	1.25	1.23	1.20	1.18	1.15	1.13	1.10
	C=1	1.65	1.50	1.45	1.40	1.34	1.30	1.26	1.22	1.20	1.17	1.13
10,870	C=0.6	1.30	1.28	1.25	1.23	1.20	1.18	1.16	1.14	1.12	1.11	1.08
	C=0.8	1.52	1.42	1.36	1.32	1.28	1.25	1.22	1.18	1.16	1.14	1.11
	C=1	1.74	1.55	1.48	1.42	1.36	1.33	1.30	1.25	1.20	1.18	1.13
11,600	C=0.6	1.39	1.31	1.28	1.25	1.21	1.20	1.18	1.15	1.13	1.11	1.08
	C=0.8	1.58	1.45	1.39	1.35	1.30	1.27	1.24	1.20	1.18	1.15	1.11
	C=1	1.81	1.61	1.53	1.46	1.39	1.36	1.31	1.26	1.22	1.20	1.14
12,320	C=0.6	1.42	1.34	1.30	1.27	1.23	1.21	1.19	1.16	1.14	1.12	1.09
	C=0.8	1.63	1.49	1.42	1.38	1.32	1.29	1.26	1.22	1.19	1.16	1.12
	C=1	1.90	1.67	1.57	1.50	1.42	1.39	1.34	1.28	1.24	1.21	1.15
13,050	C=0.6	1.46	1.36	1.32	1.28	1.25	1.22	1.20	1.17	1.15	1.13	1.09
	C=0.8	1.69	1.53	1.46	1.40	1.34	1.31	1.28	1.23	1.20	1.18	1.13
	C=1	2.00	1.73	1.62	1.54	1.46	1.41	1.36	1.30	1.26	1.22	1.16
13,770	C=0.6	1.49	1.39	1.34	1.30	1.26	1.24	1.21	1.18	1.15	1.14	1.10
	C=0.8	1.75	1.57	1.49	1.43	1.37	1.34	1.30	1.25	1.21	1.19	1.14
	C=1	2.11	1.80	1.68	1.59	1.49	1.44	1.39	1.32	1.27	1.24	1.17
14,500	C=0.6	1.53	1.41	1.36	1.32	1.28	1.25	1.22	1.19	1.16	1.14	1.11
	C=0.8	1.81	1.61	1.53	1.46	1.39	1.36	1.31	1.26	1.22	1.20	1.14
	C=1	2.24	1.87	1.73	1.63	1.53	1.48	1.41	1.34	1.29	1.25	1.18
15,220	C=0.6	1.56	1.44	1.39	1.34	1.29	1.27	1.24	1.20	1.17	1.15	1.11
	C=0.8	1.88	1.66	1.56	1.50	1.42	1.38	1.33	1.28	1.24	1.21	1.15
	C=1	2.38	1.95	1.79	1.68	1.56	1.51	1.44	1.36	1.31	1.27	1.19
15,950	C=0.6	1.60	1.47	1.41	1.36	1.31	1.28	1.25	1.21	1.18	1.16	1.12
	C=0.8	1.96	1.71	1.60	1.53	1.44	1.40	1.35	1.29	1.25	1.22	1.16
	C=1	2.55	2.04	1.86	1.73	1.60	1.54	1.47	1.38	1.33	1.28	1.20
16,670	C=0.6	1.64	1.50	1.43	1.36	1.33	1.30	1.26	1.22	1.19	1.17	1.12
	C=0.8	2.04	1.76	1.64	1.56	1.47	1.43	1.37	1.31	1.26	1.23	1.17
	C=1	2.75	2.13	1.93	1.79	1.64	1.58	1.50	1.41	1.34	1.30	1.21
17,400	C=0.6	1.69	1.53	1.46	1.40	1.34	1.31	1.28	1.23	1.20	1.18	1.13
	C=0.8	2.13	1.81	1.69	1.60	1.50	1.45	1.39	1.33	1.28	1.24	1.18
	C=1	3.00	2.24	2.00	1.84	1.69	1.61	1.53	1.43	1.36	1.31	1.22
18,120	C=0.6	1.73	1.56	1.48	1.43	1.36	1.33	1.29	1.24	1.21	1.18	1.13
	C=0.8	2.24	1.87	1.73	1.63	1.53	1.48	1.41	1.34	1.29	1.25	1.18
	C=1	3.32	2.35	2.08	1.91	1.73	1.65	1.56	1.45	1.38	1.33	1.24
18,850	C=0.6	1.78	1.59	1.51	1.45	1.38	1.35	1.30	1.25	1.22	1.19	1.14
	C=0.8	2.35	1.93	1.78	1.67	1.56	1.50	1.44	1.36	1.30	1.27	1.19
	C=1	3.74	2.49	2.17	1.97	1.78	1.69	1.59	1.48	1.40	1.35	1.25
19,570	C=0.6	1.83	1.62	1.54	1.47	1.40	1.36	1.32	1.27	1.23	1.20	1.15
	C=0.8	2.48	2.00	1.83	1.71	1.59	1.53	1.46	1.38	1.32	1.28	1.20
	C=1	4.36	2.65	2.27	2.04	1.83	1.73	1.62	1.50	1.42	1.36	1.26
20,300	C=0.6	1.88	1.66	1.56	1.50	1.42	1.38	1.33	1.28	1.24	1.21	1.15
	C=0.8	2.63	2.07	1.88	1.75	1.62	1.55	1.48	1.39	1.33	1.29	1.21
	C=1	5.39	2.83	2.38	2.12	1.88	1.78	1.66	1.53	1.44	1.38	1.27
21,020	C=0.6	1.94	1.69	1.59	1.52	1.44	1.40	1.35	1.29	1.25	1.22	1.16
	C=0.8	2.80	2.15	1.94	1.80	1.65	1.58	1.50	1.41	1.35	1.30	1.22
	C=1	7.68	3.05	2.50	2.21	1.94	1.82	1.69	1.55	1.46	1.40	1.28
21,750	C=0.6	2.00	1.73	1.62	1.54	1.46	1.41	1.36	1.30	1.26	1.23	1.16
	C=0.8	3.00	2.24	2.00	1.84	1.69	1.61	1.53	1.43	1.36	1.31	1.23
	C=1	-	3.32	2.65	2.30	2.00	1.87	1.73	1.58	1.48	1.41	1.29
22,470	C=0.6	2.06	1.77	1.65	1.57	1.48	1.43	1.38	1.31	1.27	1.24	1.17
	C=0.8	3.25	2.33	2.06	1.89	1.72	1.65	1.55	1.45	1.38	1.33	1.23
	C=1	-	3.66	2.80	2.40	2.06	1.92	1.77	1.61	1.51	1.43	1.30
23,200	C=0.6	2.13	1.81	1.69	1.60	1.50	1.45	1.39	1.33	1.28	1.24	1.18
	C=0.8	3.55	2.43	2.13	1.94	1.76	1.67	1.58	1.47	1.39	1.34	1.24
	C=1	-	4.12	3.00	2.52	2.13	1.98	1.81	1.64	1.53	1.45	1.31
23,920	C=0.6	2.21	1.86	1.72	1.62	1.52	1.47	1.41	1.34	1.29	1.25	1.18
	C=0.8	3.96	2.55	2.21	2.00	1.80	1.71	1.60	1.49	1.41	1.35	1.25
	C=1	-	4.80	3.23	2.65	2.21	2.04	1.86	1.67	1.55	1.47	1.33

Large screw connections to be assembled easily and quickly



Use of common dynamometric screwdrivers (up to approx. 100 Nm) even with big screws, e.g. M42 thread
Benefits with costs (easy and quick assembly or disassembly, respectively, no need for special tools).
Optimum load of screws, because they are only loaded with extension (no torsional load like with usual screw connections).
Ideal for narrow assemblies (e.g. gearbox housings), since it is not necessary to use large tools.
For screw property classes 8.8 and 10.9.
Mounting Instructions under www.ktr.com

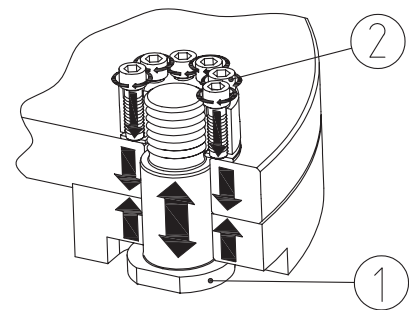
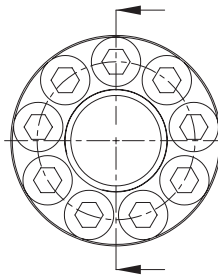
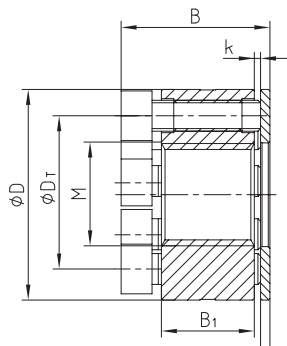

Clamping nut

CLAMPEX® – KTR 131

Size	Dimensions [in]						Pressure Screw		Property Class 8.8		Property Class 10.9	
	D	D _T	B	B ₁	s	k	DIN EN ISO 4762	Number	Tightening Torque [lb-in]	Prestress (1bf)	Tightening Torque [lb-in]	Prestress (1bf)
M24	2.0	1.5	1.4	0.8	0.12	.04 - .08	M8	8	186	39,150	266	56,020
M27	2.2	1.7	1.6	1.0	0.12	.04 - .08	M8	9	212	50,400	266	63,000
M30	2.5	1.9	1.7	1.0	0.12	.04 - .08	M10	8	363	61,650	531	90,220
M33	2.6	2.0	1.9	1.2	0.12	.04 - .08	M10	9	398	76,050	531	101,470
M36	3.1	2.3	2.0	1.2	0.12	.04 - .08	M12	8	62	89,100	929	131,850
M42	3.3	2.5	2.2	1.4	0.12	.04 - .08	M12	10	690	122,400	929	164,700
M48	3.5	2.8	2.4	1.6	0.12	.04 - .08	M12	11	841	162,220	929	181,350
M52	3.9	3.1	2.6	1.7	0.18	.04 - .08	M12	13	841	193,950	929	214,200
M56	4.3	3.3	3.0	1.8	0.18	.04 - .08	M16	9	1,859	225,220	2,213	268,200
M60	4.4	3.4	3.2	1.9	0.18	.04 - .08	M16	10	1,903	256,270	2,213	298,120
M64	4.7	3.6	3.3	2.0	0.31	.04 - .08	M16	11	1,991	272,470	2,213	327,820
M72	5.6	4.2	3.9	2.3	0.31	.04 - .08	M20	10	3,540	381,600	4,437	467,320
M80	6.5	4.8	4.1	2.5	0.31	.04 - .08	M20	12	3,717	480,820	4,437	560,920

Use on a 100 kNm test bench bottle



Use of couplings for wind power stations



Also available as a complete unit including set screw



Order form:

KTR clamping nut	M33 x 3,5
Type	Size